



**British
Geological Survey**

NATURAL ENVIRONMENT RESEARCH COUNCIL

DFID Department For
International
Development

Simple methods for assessing groundwater resources in low permeability areas of Africa

Groundwater systems and water quality

Commissioned Report CR/01/168N



BRITISH GEOLOGICAL SURVEY

COMMISSIONED REPORT CR/01/168N

Simple methods for assessing groundwater resources in low permeability areas of Africa

A M MacDonald, J Davies and B É Ó Dochartaigh

Key words

Africa; groundwater;
hydrogeology; assessment.

Front cover

Community members helping
assess the yield of a borehole in
Edumoga village, Nigeria.

Bibliographical reference

MACDONALD, A M, DAVIES, J
AND Ó DOCHARTAIGH, B É
2002. Simple methods for
assessing groundwater resources
in low permeability areas of
Africa. *British Geological Survey
Commissioned Report*,
CR/01/168N. 71pp.

BRITISH GEOLOGICAL SURVEY

The full range of Survey publications is available from the BGS Sales Desks at Nottingham and Edinburgh; see contact details below or shop online at www.thebgs.co.uk

The London Information Office maintains a reference collection of BGS publications including maps for consultation.

The Survey publishes an annual catalogue of its maps and other publications; this catalogue is available from any of the BGS Sales Desks.

The British Geological Survey carries out the geological survey of Great Britain and Northern Ireland (the latter as an agency service for the government of Northern Ireland), and of the surrounding continental shelf, as well as its basic research projects. It also undertakes programmes of British technical aid in geology in developing countries as arranged by the Department for International Development and other agencies.

The British Geological Survey is a component body of the Natural Environment Research Council.

Keyworth, Nottingham NG12 5GG

☎ 0115-936 3241 Fax 0115-936 3488
e-mail: sales@bgs.ac.uk
www.bgs.ac.uk
Shop online at: www.thebgs.co.uk

Murchison House, West Mains Road, Edinburgh EH9 3LA

☎ 0131-667 1000 Fax 0131-668 2683
e-mail: scotsales@bgs.ac.uk

London Information Office at the Natural History Museum (Earth Galleries), Exhibition Road, South Kensington, London SW7 2DE

☎ 020-7589 4090 Fax 020-7584 8270
☎ 020-7942 5344/45 email: bgs london@bgs.ac.uk

Forde House, Park Five Business Centre, Harrier Way, Sowton, Exeter, Devon EX2 7HU

☎ 01392-445271 Fax 01392-445371

Geological Survey of Northern Ireland, 20 College Gardens, Belfast BT9 6BS

☎ 028-9066 6595 Fax 028-9066 2835

Maclean Building, Crowmarsh Gifford, Wallingford, Oxfordshire OX10 8BB

☎ 01491-838800 Fax 01491-692345

Parent Body

Natural Environment Research Council, Polaris House, North Star Avenue, Swindon, Wiltshire SN2 1EU

☎ 01793-411500 Fax 01793-411501
www.nerc.ac.uk

Preface

Helping to meet International Development Targets is the number one challenge for the water sector. To increase access to sustainable supplies of safe water for the poor, groundwater resources need to be exploited successfully, sustainably and economically on a much larger scale than they are now.

Exploiting groundwater on a larger scale requires knowledge to be transferred more widely and effectively. Unfortunately, techniques for finding and exploiting groundwater are often hidden in scientific journals or project reports, and not widely disseminated. This manual aims to be a first step in providing useful information for project engineers working on rural water supply projects in sub-Saharan Africa. The focus of the manual is on low permeability aquifers, where groundwater is difficult to find. The techniques have been tested by the British Geological Survey for their effectiveness and by WaterAid staff for usability. However the manual is not static and suggestions and comments would be most welcome for future editions.

The manual is an output from a U.K. Department for International Development project (R7353 – Groundwater from low permeability rocks in sub Saharan Africa).

Alan MacDonald
April 2002

Acknowledgements

Many individuals both in BGS and elsewhere contributed to the development of this manual. Much of the material has been tested and improved by WaterAid staff in Nigeria, Ghana or Tanzania. Colleagues at BGS also provided advice and helpful comments. Thanks to DFID for providing funding for the project

British Geological Survey

John Chilton:	reviewing the manual
Jude Cobbing	editing
Roger Peart	advice on geophysical aspects
Dave Beamish	advice on geophysical modelling

WaterAid

Nick Burn (London)
Kitka Goyol (Nigeria)
Gordon Mumbo (Ghana)
Herbert Kasililah (Tanzania)

Thanks also to Petros Eikon® for providing the geophysical modelling software and Prof John Barker (University College London) for his helpful comments on the bailer test.

Contents

Preface i

Acknowledgements ii

Contents iii

1 Introduction 1

2 Groundwater resources in sub-Saharan Africa 2

2.1 Why groundwater? 2

2.2 Groundwater resources in SSA 2

3 Reconnaissance 7

3.1 Experience 7

3.2 observations - geology and previous success 7

3.3 Maps and reports 7

3.4 Siting boreholes and villages on maps 7

3.5 further techniques 8

4 Techniques for siting wells and boreholes 9

4.1 Geological Triangulation – maps, observation and geophysics 9

4.2 Community discussions and village observation 10

4.3 When are geophysical techniques required? 10

4.4 Ground conductivity using FEM 12

4.5 Electrical resistivity 20

4.6 Further techniques 22

5 Gathering information during drilling 25

5.1 What are boreholes and wells? 25

5.2 Drilling methods and equipment 25

5.3 Drilling and sampling procedures 27

5.4 Data collection during drilling 29

6 Assessing the yield of a borehole 35

6.1 Why carry out a pumping test in a borehole? 35

6.2 Measuring yield during an airlift 35

6.3 The bailer test 36

6.4 Constant rate tests 38

7 Simple methods for assessing groundwater quality 41

7.1 Groundwater quality 41

7.2 Simple measures of water quality 43

7.3 Detailed analysis 44

8 Using the information to build a regional picture 45

8.1 Why is understanding the regional hydrogeology useful? 45

8.2 Keeping hold of information 45

8.3 A simple database 45

8.4 The future? 46

Appendix 1 Fact sheets on techniques and methods 47

FIGURES

Figure 1.1 Understanding the groundwater resources can mean the difference between successful and unsuccessful boreholes. 1

Figure 2.1 Groundwater provinces in sub-Saharan Africa. 2

Figure 2.2 Land area and rural population of the different hydrogeological zones of SSA. 3

Figure 2.3 Variation of permeability and porosity with depth in basement aquifers (based on Chilton & Foster, 1995). 3

Figure 2.4 Cross section of groundwater flow in highland volcanic areas. 4

Figure 2.5 Groundwater occurrence in consolidated sedimentary rocks. 4

Figure 2.6 Groundwater occurrence in unconsolidated sedimentary rocks. 5

Figure 3.1 A GPS being used by WaterAid project staff in Nigeria. 8

Figure 4.1 Siting wells and boreholes in areas where it is easy to find groundwater, where groundwater occurrence is generally understood, and in complex areas. 9

Figure 4.2 The geological triangulation method. 9

Figure 4.3 Places to visit on a reconnaissance visit to a community. 10

Figure 4.4 How ground conductivity methods work. 12

Figure 4.5 The different possible orientations of FEM equipment. 12

Figure 4.6 Choosing survey lines in a community. 13

Figure 4.7 Example of a notebook for a ground conductivity survey using EM34 equipment. 13

Figure 4.8 The EM34 equipment, comprising two coils, a connecting cable, transmitter and receiver. 14

Figure 4.9 The EM34 being used with the coils horizontal. 14

Figure 4.11 Resistivity and conductivity of common rock types. 15

Figure 4.12 Ground conductivity measured using the EM34 instrument over a pocket of weathered basement rocks. 16

Figure 4.13 Apparent conductivity measured over increasing thicknesses of weathered basement using different coil spacings and orientations. 17

Figure 4.14 Response of the EM34 instrument over a single vertical conductor. 17

Figure 4.15 Schematic diagram showing the kind of response that is given by ground conductivity (using the EM34 instrument) over fracture zones in basement. 18

Figure 4.16 Using ground conductivity to map out the boundary between a sandstone and a mudstone in a village. 19

Figure 4.17 The three main electrode configurations for carrying out VES. 20

Figure 4.18 Equipment for carrying out resistivity surveys. 21

Figure 4.19 Electrodes have to be hammered in and sometimes watered to ensure good electrical contact with the ground. 21

Figure 4.20 The instrument stays at the midpoint and cables run out to either side. 21

Figure 4.21 Common resistivity curves and their interpretation for basement areas 23

Figure 4.22 Simple resistivity curves and a rough interpretation for sedimentary areas. 24

Figure 5.1 Component parts of a typical borehole. 25

Figure 5.2 A typical hand-dug well. 25

Figure 5.3 Community members standing too close to a drilling rig for safety. 27

Figure 5.4 Equipment required for collecting and analysing data during drilling. 28

Figure 5.5 Example of field notebook for assessing drilling conditions. 29

Figure 5.6 Rock chip samples stored in clearly marked plastic bags. 30

Figure 5.7 Rock chip samples stored separately, in order of collection. 30

Figure 5.8 A cored sample showing an open fracture in limestone, associated with calcite veining. 31

Figure 5.9 Example of rock chip samples displayed in a sectioned pipe. 31

Figure 5.10 An example of the information that can be collected from a routine water supply borehole using some of the simple techniques described in this chapter. 32

Figure 5.11 Typical borehole completion diagram, showing lithological and construction details. 33

Figure 6.1 Measuring yield during airlift. 35

Figure 6.2 Community members helping with a bailer test in Edumoga, Nigeria, 36

Figure 6.3 Equipment required for a bailer test. 36

Figure 6.4 Carrying out a pumping test using Whale pumps powered from a car battery. 38

Figure 6.5 Example of a notebook recording water-levels during a constant rate pumping test. 39

Figure 6.6 An example of measuring s' from recovery data. 39

Figure 6.7 Measuring s from a drawdown curve. 40

Figure 6.8 Any deviations from a straight line in a Jacob plot can give useful information about an aquifer. 40

Figure 7.1 Simple field equipment for estimating water quality. 43

Figure 7.2 Highly corroded rising main from a borehole with TDS greater than 3000 mg/l. New rising main corroded within one year. 44

Figure 8.1 Project staff using a groundwater development map produced on a GIS using the techniques described in this manual. 46

BOXES

Box 3.1 Questions to discuss with someone with previous experience of the project area. 7

Box 3.2 A first field visit. 7

Box 4.1 Summary for surveys to identify deep weathering in basement. 16

Box 4.2 Summary of surveying for fracture zones in basement rocks. 17

Box 4.3 Summary of surveying with ground conductivity in sedimentary environments. 19

Box 4.4 Resistivity and Conductivity 22

Box 4.5 Summary of resistivity VES. 22

Box 6.1 Criteria for success used in the bailer test 37

TABLES

Table 2.1 Summary of groundwater potential of groundwater domains in sub-Saharan Africa with indicative costs of development. 6

Table 3.1 Information available from different organisations. 8

Table 4.1 Summary of common geophysical techniques used in groundwater investigations (from MacDonald *et al.* 2000). 11

- Table 4.2 Electrical conductivity of different mudstones measured in Nigeria. 19
- Table 4.3 Advantages and disadvantages of using resistivity VES. 20
- Table 5.1 Summary of drilling methods and their applicability to different environments. 26
- Table 6.1 Advantages and disadvantages of measuring yield during airlift. 36
- Table 6.2 Table for assessing the success of a borehole from a bailer test. If the maximum drawdown and time for half and three quarters recovery are all less than quoted here (for the correct borehole diameter and pumping rate) then the borehole is likely to be successful. 37
- Table 7.1 World Health Organisation guidelines for drinking water quality: inorganic chemicals of health significance in drinking water. 41
- Table 7.2 World Health Organisation guidelines for drinking water quality: inorganic substances and parameters in drinking water that may give rise to complaints from customers. 42

1 Introduction

In many areas throughout Africa, a staggering proportion of wells and boreholes fail. Failure can occur for a number of reasons – inadequate maintenance and community involvement, poor engineering or a lack of water. Often it can be difficult to work out the exact reason after the event. However, in many geological environments the impacts of poorly sited and designed boreholes and wells are a major concern to funding agencies, implementing institutions and local communities. In such areas, good supplies of groundwater cannot be found everywhere, and boreholes and wells must be sited and designed carefully to make use of the available groundwater. To appropriately site and design water sources, the groundwater resources of an area need first to be investigated to understand how water occurs in the ground.

In this manual we present some techniques that allow a quick assessment of groundwater resources without requiring much expertise or expense. Some of the techniques are old and established while others are new. However, all techniques have been tested by BGS (and others) in assessing groundwater resources in Africa. This manual does not claim to be a detailed textbook for hydrogeologists – there are enough already (see reading list at the end of the chapter). Rather it is meant as a practical aid for those involved in the practice of rural water supply, particularly in Africa. Little training or equipment is required for the tests and they can all be carried out in a

short space of time.

The manual is divided into six sections. The first gives an overview of the groundwater resources of sub-Saharan Africa (SSA) and discusses the scope and detail of investigations required in different geological environments. The remaining chapters describe simple techniques for assessing groundwater resources, from basic reconnaissance to assessing the yield of a borehole. In the appendix are summary sheets of the most common techniques which can be photocopied and used in the field.

FURTHER READING ON HYDROGEOLOGY

Price M. 1996. *Introducing Groundwater*. Stanley Thornes, 278 pp

Freeze, R A, and Cherry, J A, 1979. *Groundwater*. Prentice Hall, Englewood Cliffs

Fetter, C W, 1994. *Applied Hydrogeology*. Macmillan, New York.



Figure 1.1 Understanding the groundwater resources can mean the difference between successful and unsuccessful boreholes.

2 Groundwater resources in sub-Saharan Africa

2.1 WHY GROUNDWATER?

Groundwater is well suited to rural water supply in sub-Saharan Africa (SSA). Since groundwater responds slowly to changes in rainfall, the impacts of droughts are often buffered. In areas with a long dry season, groundwater is still available when sources such as rivers and streams have run dry. The resource is relatively cheap to develop, since large surface reservoirs are not required and water sources can usually be constructed close to areas of demand. These characteristics make groundwater well suited to the more demand-responsive and participatory approaches that are being introduced into most rural water and sanitation programmes.

Groundwater has excellent natural microbiological

quality and generally adequate chemical quality for most uses. Nine major chemical constituents (Na, Ca, Mg, K HCO₃, Cl, SO₄, NO₃ and Si) make up 99% of the solute content of natural groundwaters. The proportion of these constituents reflects the geology and history of the groundwater. Minor and trace constituents make up the remaining 1% of the total, and their presence (or absence) can occasionally give rise to health problems or make them unacceptable for human or animal use.

2.2 GROUNDWATER RESOURCES IN SSA

Figure 2.1 shows a hydrogeological map of SSA. Broadly, SSA can be divided into four hydrogeological provinces: Precambrian “basement” rocks; volcanic rocks; unconsolidated sediments; and consolidated sedimentary

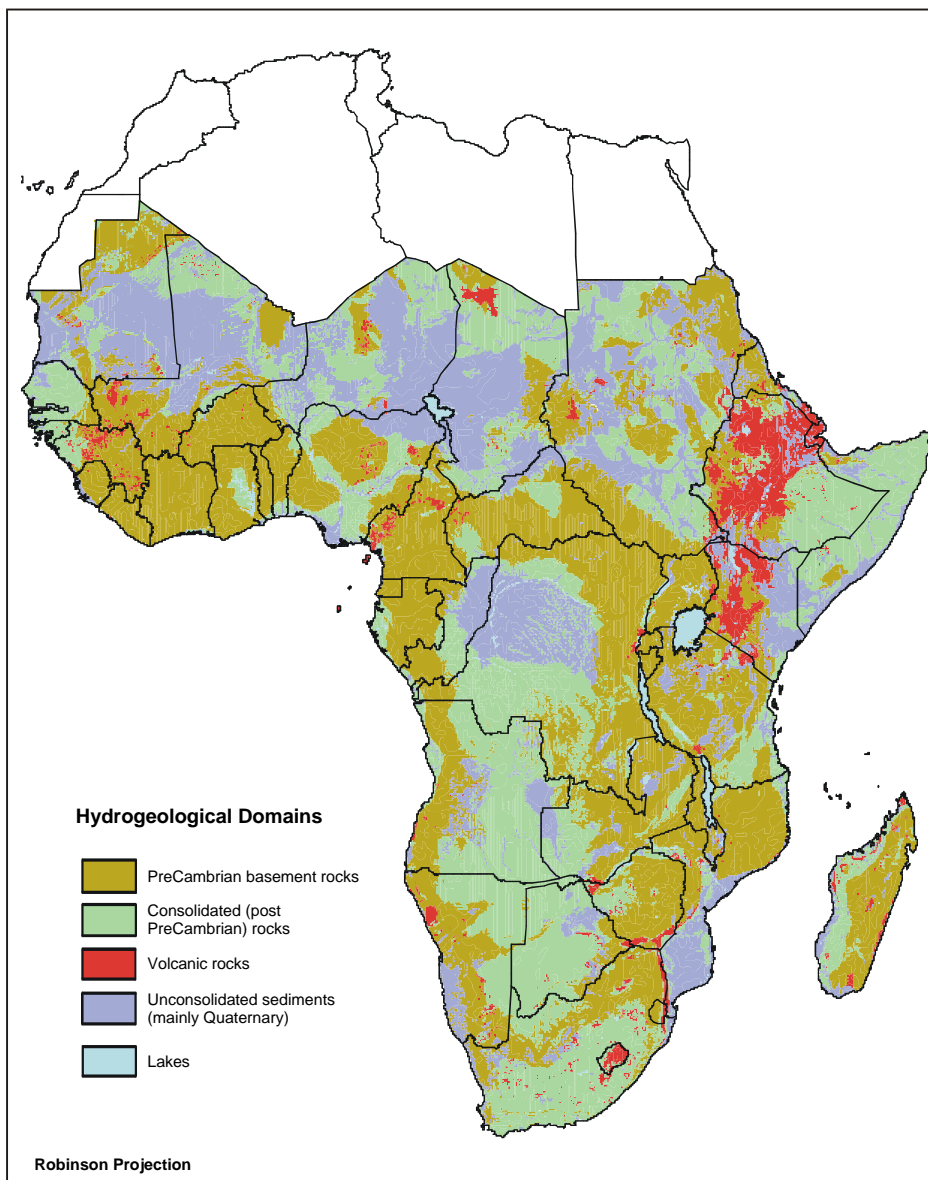

Figure 2.1 Groundwater provinces in sub-Saharan Africa.

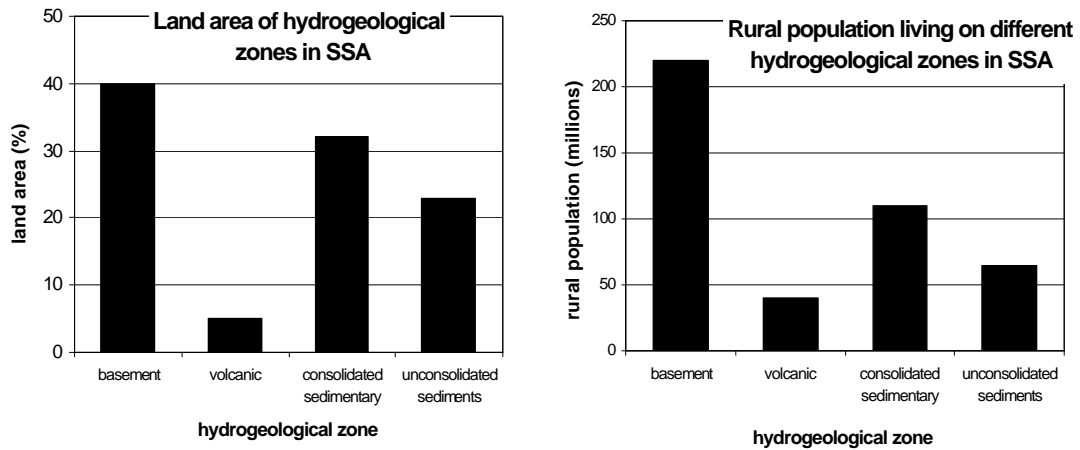

Figure 2.2 Land area and rural population of the different hydrogeological zones of SSA.

rocks. Groundwater occurs in different ways in these four provinces, and different methods are required to find and sustainably develop groundwater in each. Basement rocks form the largest hydrogeological province, occupying 40% of the 23.6 million square kilometres of SSA (Figure 2.2); volcanic rocks are the smallest hydrogeological province with only 6% of the land area. The relative importance of the hydrogeological provinces is best indicated by the rural population living in each one. Rural communities are most dependent on local resources for water supply, since transporting water over significant distances is prohibitively expensive and difficult to manage. Figure 2.2 shows the number of rural people living in each of the four main hydrogeological provinces in SSA.

A brief description of each hydrogeological zone is given below. This is a summary of information given in a companion report describing the hydrogeology of sub-

Saharan Africa (MacDonald & Davies 2000).

1. Crystalline basement rocks occupy 40% of the land area of SSA; 220 million people live in rural areas underlain by crystalline basement rocks. They comprise hard crystalline rocks such as granite and metamorphic rocks. The occurrence of groundwater depends on the existence of a thick weathered zone (the uppermost 10 - 30 m) or deeper fracture zones (Figure 2.3). Much of the weathered basement has been weathered or fractured. Groundwater in the shallow weathered zone can be exploited with boreholes, dug wells and collector wells; groundwater in the deeper fracture zones can only be exploited using boreholes. Borehole and well yields are generally low, but usually sufficient for rural demand. Good sites for wells and boreholes can be found using

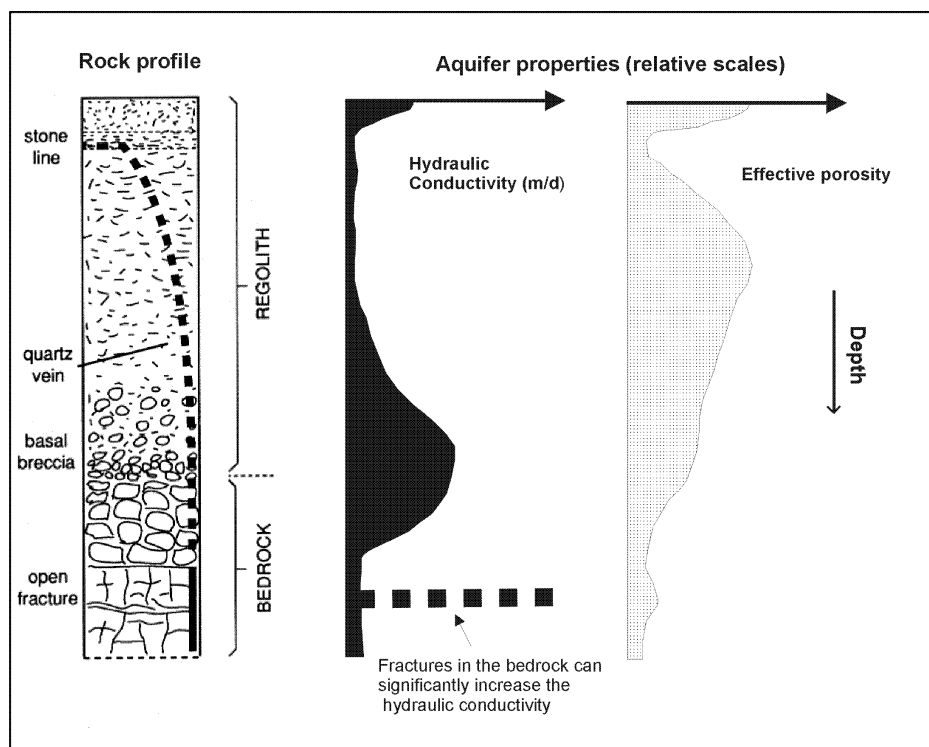

Figure 2.3 Variation of permeability and porosity with depth in basement aquifers (based on Chilton & Foster, 1995).

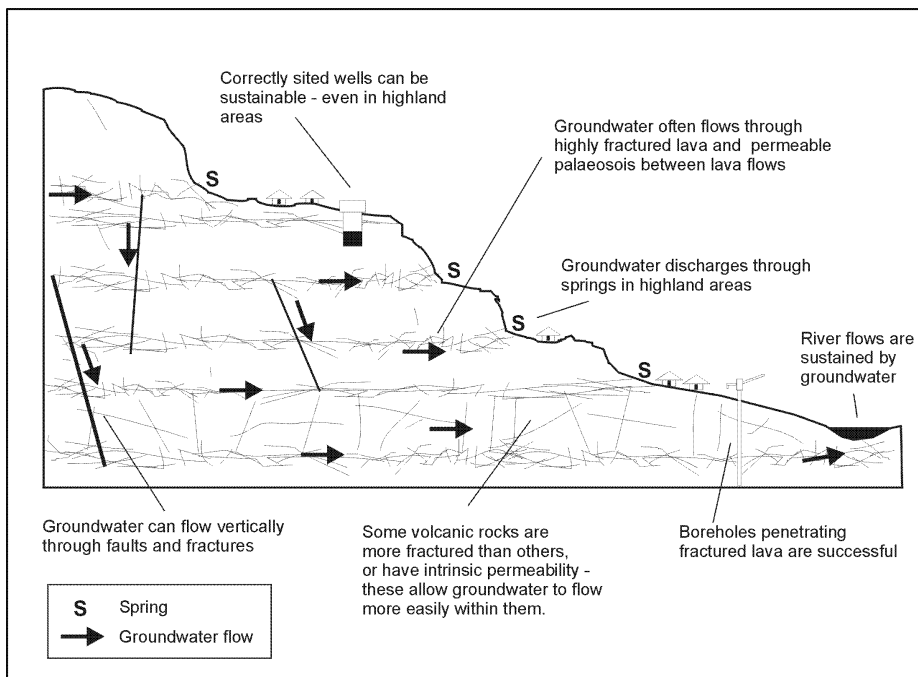

Figure 2.4 Cross section of groundwater flow in highland volcanic areas.

standard geophysical techniques. Groundwater is generally of good quality (occasional elevated sulphate, iron or manganese), but is vulnerable to contamination.

2. Volcanic rocks occupy 6% of the land area of SSA, and sustain a rural population of 45 million, many of whom live in the drought stricken areas of the Horn of Africa. Hard black basalts and ash deposits make up many of the volcanic rocks. Groundwater occurs in zones of fracturing between individual lava flows and within volcanic rocks which have themselves been highly fractured or are porous (Figure 2.4). Yields can

be highly variable, but are on average sufficient for rural domestic supply and small scale irrigation. Groundwater in mountainous areas can be exploited through springs, wells and boreholes. Where the rocks are hard and the fracture zones deep, only boreholes are possible. Geophysical methods are not routinely used to site boreholes and wells, but may be valuable in certain circumstances. Groundwater quality can sometimes be poor due to high fluoride concentrations.

3. Consolidated sedimentary rocks occupy 32% of the land area of SSA and sustain a rural population of 110 million. Consolidated sedimentary rocks comprise

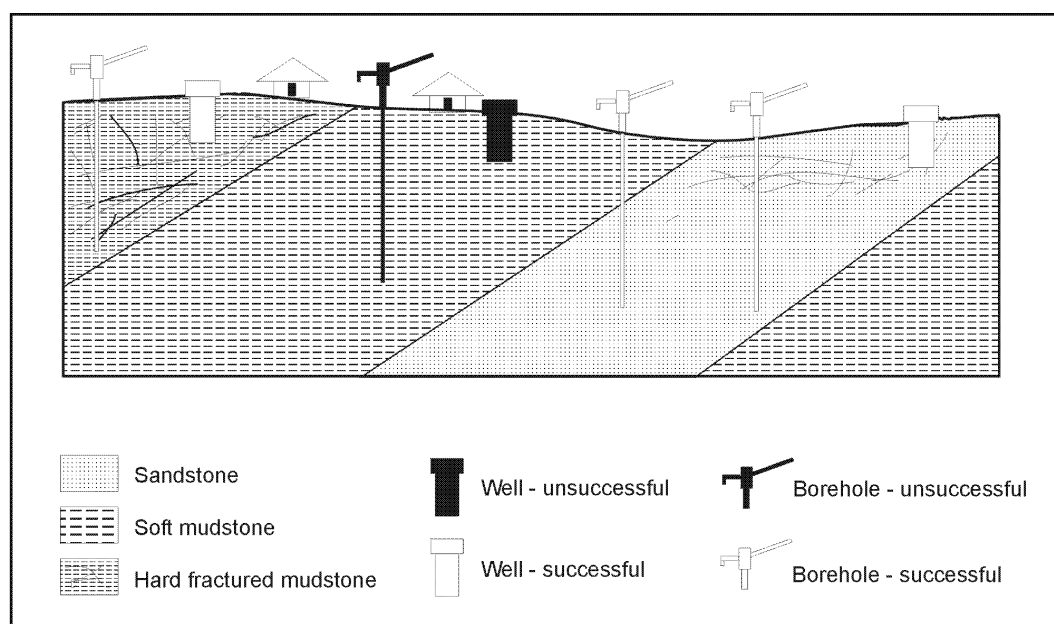

Figure 2.5 Groundwater occurrence in consolidated sedimentary rocks.

sandstone, limestone and mudstone and often form thick extensive sequences. Sandstone often contains large amounts of groundwater, particularly where fractured or friable; limestone can also contain significant groundwater. Mudstones, which may comprise up to 65% of all sedimentary rocks are poor aquifers, but groundwater can still sometimes be found in harder more fractured mudstone (Figure 2.5). Where aquifers and groundwater levels are shallow, wells can be used. However where the aquifers are deep, boreholes must be used and need to be carefully constructed and gravel packed to avoid ingress of sand. Geophysical methods can easily distinguish sandstone from mudstone and between hard and soft mudstone. Where sandstone or limestone aquifers are extensive and/or shallow, careful siting is often not required for domestic water supplies. Groundwater quality is generally good, but can be saline at depth, or have localised elevated sulphate, iron or manganese.

- Unconsolidated sediments cover 22% of the landmass of SSA; at least 60 million rural people live on these sediments, but many of those living on less productive rocks types are close to small unconsolidated sedimentary aquifers (UNSA) associated with river valleys. UNSAs comprise a range of material from coarse gravel to silt and clay. Groundwater is found within gravel and sand layers (Figure 2.6). Yields from thick deposits of sand and gravel can be high, sufficient for domestic supply and agricultural irrigation. Where aquifers and groundwater levels are shallow, wells can be used and boreholes installed using hand drilling. However where the aquifers are deep, boreholes must be used and need to be carefully constructed and gravel packed to avoid ingress of sand. Geophysical methods can easily distinguish sand and gravel layers and can be used to indicate the thickness

of UNSAs. In large UNSAs, little siting is required. Groundwater quality problems can occur in UNSAs due to natural geochemistry and contamination, such as high iron, arsenic and elevated nitrate.

There are many exceptions to the general models presented here, and areas exist in each of the hydrogeological environments where groundwater is not easily found. More research and experience is required to help refine the models and shed light on the groundwater potential of different environments. Two of the most widespread problematic areas are poorly weathered basement rocks and sedimentary mudstones. Research into the potential for groundwater in these rocks types is limited, and water projects in these areas are rarely successful.

The basic models for how groundwater occurs in the various hydrogeological environments presented above have been developed from research and experience both in Africa and other similar hydrogeological areas worldwide. Table 1 gives a summary of the current knowledge of the groundwater resources of each hydrogeological environment. Indicative costs of developing a groundwater source are given to help reflect the implications for rural water supply of the varying hydrogeological conditions and the current knowledge base of different aquifers. The technical capacity required to develop groundwater also changes with the hydrogeology: in some environments little expertise is required, while in others considerable research and money is required to develop groundwater. Throughout the remaining chapters we discuss which techniques are important for the various hydrogeological provinces.

FURTHER READING

MACDONALD, A M AND DAVIES, J. 2000. A brief review of groundwater for rural water supply in sub-Saharan Africa. British

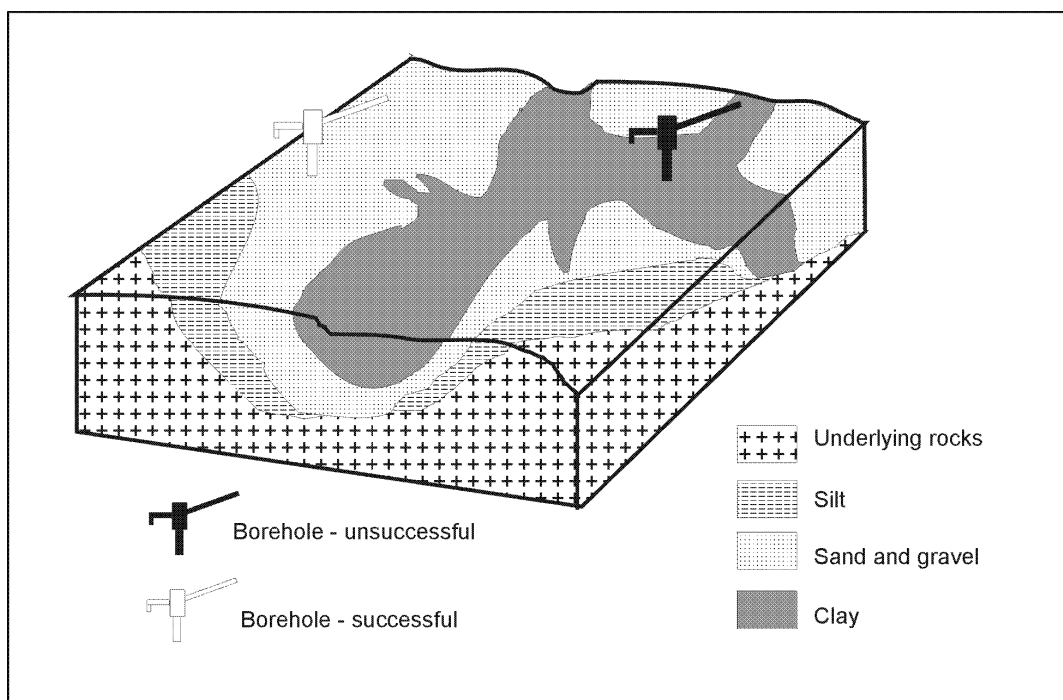

Figure 2.6 Groundwater occurrence in unconsolidated sedimentary rocks.

FOSTER, S S D, CHILTON, P J, MOENCH, M, CARDY, F AND SCHIFFLER, M. 2000. Groundwater in rural development, World Bank Technical Paper No 463, The World Bank, Washington D C.

EDMUNDS, W M AND SMEDLEY, P L. 1996. Groundwater geochemistry and health: an overview. In: Appleton, J D, Fuge, R & McCall, G J H. (eds), Environmental geochemistry and health, Geological Society Special Publications, 113, 91-105.

CHILTON, P J AND FOSTER, S S D. 1995. Hydrogeological characterisation and water-supply potential of basement aquifers

Table 2.1 Summary of groundwater potential of groundwater domains in sub-Saharan Africa with indicative costs of development.

Groundwater Domains	Groundwater Sub-Domains	Groundwater Potential	Average Groundwater Yields	Groundwater Targets	Costs* and technical difficulty** of developing groundwater sources	
					Rural Domestic Supply	Small Scale Irrigation
Basement Rocks	Highly weathered and/or fractured basement	Moderate	0.1- 1 l/s	Fractures at the base of the deep weathered zone	£ - ££ # - ##	££ - £££ ## - ###
	Poorly weathered and/or sparsely fractured basement	Low	0.1 l/s	Widely spaced fractures and pockets of deep weathering	£££ ###	Generally not possible
Volcanic Rocks	Mountainous areas	Moderate	0.5 – 5 l/s	Horizontal fracture zones between basalt layers. More fractured basalts	£ - ££ # - ###	£ - ££ # - ###
	Plains or plateaux	Moderate	0.5 – 5 l/s	Horizontal fracture zones between basalt layers. More fractured basalts	££ - £££ # - ###	££ - £££ # - ###
Consolidated sedimentary rocks	Sandstones	Moderate - High	1 – 20 l/s	Porous or fractured sandstone	£ - ££ # - ##	£ - £££ # - ##
	Mudstones	Low	0 – 0.5 l/s	Hard fractured mudstones; igneous intrusions or thin limestone/sandstone layers	££ - £££ ## - ###	Generally not possible
	Limestones	Moderate	1-10 l/s	Karstic and fractured limestones	££ - £££ ## - ###	£ - £££ # - ##
Unconsolidated sediments	Large basins	Moderate - High	1 – 20 l/s	Sand and gravel layers	£ - ££ # - ##	£ - £££ # - ##
	Small dispersed deposits, such as riverside alluvium	Moderate	1 – 20 l/s		£ - ££ # - ##	£ - £££ # - ##

*The approximate costs of siting and constructing one source, including the “hidden” cost of dry sources: £ = < £1000; ££ = £1000 to £10 000 and £££ = > £10 000.

** The technical difficulty of finding and exploiting the groundwater is roughly classified as: # = requires little hydrogeological skill; ## = can apply standard hydrogeological techniques; ### = needs new techniques or innovative hydrogeological interpretation.

3 Reconnaissance

Every good football manager and army general knows the importance of reconnaissance. Only with accurate intelligence on key parameters is it possible to plan a strategy for success. The same is true for water projects. Before a water project can be planned, key socio-economic, institutional and physical information must be gathered – in this manual we are only concerned with the physical issues. There is no point in planning a groundwater project if there is no groundwater available, or in buying sophisticated exploration equipment where groundwater is ubiquitous. In this chapter we describe some simple ways to carry out simple, effective reconnaissance.

3.1 EXPERIENCE

It is always helpful to find someone who has worked in the area before. Not only can they give their own opinion of the area, but they can help point in the direction of other projects in the area or maps and reports that might have been written. Box 3.1 gives a list of information that would be useful to discuss with someone who has experience in the area. However, all advice and information given should be treated cautiously and always checked in the field. In our experience, people can often give misleading information in their enthusiasm to be helpful.

3.2 OBSERVATIONS - GEOLOGY AND PREVIOUS SUCCESS

The first visit to a project area is very important. It is at this time that lasting impressions are made. The project is also at its most fluid in the early stages so design alterations are much easier. If possible a visit should be made when the water problems are at their worst – during the height of the dry season. Several days should be spent visiting different parts of the area, trying to get a balanced overview of the

Box 3.1 Questions to discuss with someone with previous experience of the project area.

- What was their involvement in the area?
- How easy is it to find groundwater – what was their success rate?
- What do they know about the geology?
- Do they have records/reports of borehole drilling, or the project in general?
- Ask them to draw a map of the area, showing geology and easy/difficult areas to find water.
- Any poor water quality in the area?
- What techniques would they consider for finding groundwater?
- What other projects do they know of and people knowledgeable about the area?

Box 3.2 A first field visit.

Take a GPS (see section 3.4), magnifying glass, hammer, water EC meter and any maps. If you have space also take a water-level dipper, pH meter and compass-clinometer.

Drive along main roads cutting across the area and stop where there is rock at the surface (often in river valleys). Examine and describe the rocks, and take a sample. Take a GPS reading of any stop you made so it can be marked on the map.

At representative villages discuss carefully the water supply problems. Walk to the dry season water source and try to work out why there is water there, measure the water EC and pH. Note any successful or dry wells and boreholes and measure depth, depth to water level, EC and pH. Discuss any previous unsuccessful drilling and work out the geology for the village from samples at the bottom of wells, or nearby river valleys.

Note areas (discussing with local NGOs or government officials) where there are successful wells and boreholes, and areas where boreholes and wells have been unsuccessful.

water problems in the area. This will be easier if maps can be gathered before such a visit. The aim must be to cover much ground and make a rapid assessment, rather than making a detailed assessment in only one or two areas. Box 3.2 lists information that should be gathered.

3.3 MAPS AND REPORTS

Useful information often exists hidden away on people's shelves or locked in government filing cabinets. For most areas it should be possible to gather basic information, such as topographic and geological maps. Often other information exists, such as aeromagnetic maps, aerial photographs and even hydrogeological maps. If other projects have been carried out in the area there will be project reports, and possibly databases of boreholes. Universities are also good sources of information. Geology Departments of nearby Universities will often know most about the current geology, and may have undertaken studies in the area. International consultants can often be useful sources of information and may have access to information that is now not available in country and also have access to academic literature. BGS for example has an extensive library of maps and reports from throughout the world and as a DFID resource centre offers a free enquiry service for people in developing countries. Table 3.1 lists different organisations that are useful to contact, and the information that may be available in each.

3.4 SITING BOREHOLES AND VILLAGES ON MAPS

Knowing where most of the villages are is an important part of the planning phase of a project. It is then possible to plot them on maps and therefore estimate what geology

Table 3.1 Information available from different organisations.

<i>Institution</i>	<i>Data & Information</i>
Mapping Institute	Topographic maps, aerial photographs
Geological Survey	Geological maps, aerial photographs, hydrogeological maps, aeromagnetic maps
Rural Water Department	Databases of boreholes, reports of previous projects or statewide surveys
Universities	Geological maps, local research in the area.
Local NGOs, local government	Databases of boreholes, consultant's reports, records of those who have worked in the area.
International Geological Organisations (such as BGS)	Geological maps, Consultants reports, academic literature.

underlies each village. At the reconnaissance stage this gives a good idea of the proportion of villages underlain by each geological unit. In the same manner each improved water source (such as borehole or improved well) can be located on maps, and each abandoned borehole. This will help assess which areas are easy to find groundwater and which are difficult.

With the advent of GPS (global positioning system) it is now very easy to locate wells and villages on maps. GPS are small inexpensive pieces of equipment about the size of a mobile phone or calculator (Figure 3.1). When switched on they track the position of satellites and from this information can accurately locate where they are on the ground. They can give a read out in decimal degrees or in many local grid systems. For greatest accuracy they should be set up to the same grid system as the maps on which the information will be plotted.

3.5 FURTHER TECHNIQUES

3.5.1 Satellite interpretation

It is sometimes useful to use information from satellites to help create a base map for the area. This is a specialised technique and will require the input of a good consultant or university. A satellite image contains information from the light spectrum and is interpreted to help give an indication of changing conditions on the ground. Under good conditions changes in geology can sometimes be observed. Fracture zones, rivers and roads are interpretable with experience. Information from satellite images can be presented on maps at about 1:50 000 scale. Although useful for a reconnaissance of an area, satellite images cannot normally be used by themselves for siting wells or boreholes.



Figure 3.1 A GPS being used by WaterAid project staff in Nigeria.

3.5.2 Geographical information systems (GIS)

GIS are excellent tools for water supply projects. They allow map information to be combined, analysed and presented in many different ways. This means that tailor made maps can be easily created for different project stakeholders. However, to set up a GIS demands specific expertise and considerable effort to get all the data in the appropriate format. Universities and consultants however should be able to carry out this work.

To create a GIS for an area available data are put into digital form. That means digitising topographic and geological maps and making sure they are in the same map registration. Once this is done other information, such as village locations can be added and plotted on top. Once some investigations have been done preliminary groundwater potential maps could be drawn up and printed for use in the field.

4 Techniques for siting wells and boreholes

Of all techniques in this manual, this is the most dependent on geology type. A technique that may give 90% success in one geological environment may be worse than useless in another. No technique or piece of equipment is consistently useful in all environments. Different hydrogeological environments also demand different levels of siting. Where groundwater is easily found (Figure 4.1) little siting is required for wells and boreholes and hydrogeological considerations are of little priority. In other areas groundwater is not ubiquitous, but siting methods are well established and standard techniques can be used (e.g. weathered basement rocks). However, there are many hydrogeological environments which are complex and no standard techniques are available for siting wells and boreholes. In these areas, geophysical and other techniques must be tested to provide new rules of thumb that are

Figure 4.1 Siting wells and boreholes in areas where it is easy to find groundwater, where groundwater occurrence is generally understood, and in complex areas.

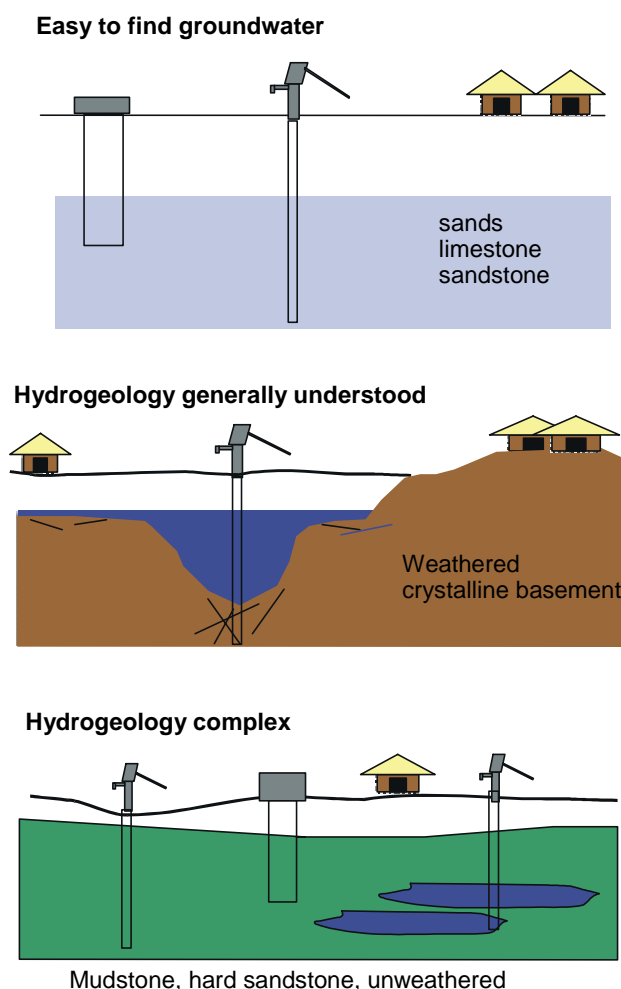

appropriate for that environment.

In this chapter we describe several useful techniques for siting wells and boreholes, and rules of thumb for interpreting data in most hydrogeological environments.

4.1 GEOLOGICAL TRIANGULATION – MAPS, OBSERVATION AND GEOPHYSICS

For an accurate assessment of the potential for groundwater at a village it is important not to rely on just one technique or approach. Maps can often be wrong, community discussions can be misleading and geophysical surveys cannot be interpreted properly unless the geological environment is known first. An approach that has been used successfully in many groundwater projects is to use a combination of maps, observation and geophysics. We have called it geological triangulation.

1. **Maps.** Villages should be located accurately on available geological and topographic maps. The coordinates of each village are determined using a global positioning system (GPS). Once located, the map provides an indication of the basic geology at the village site.
2. **Observation.** The local geology must be examined with care and discussed with the local community. The nature of the rocks should be noted. Local wet and dry season sources of water need to be visited, as should any locations that the community considers as possible groundwater sources. Rock samples need to be collected from local rock exposures; and rock spoil from shallow wells examined. More information on carrying out village observation is given in Section 4.2. This geological information should be used to up-date scanty map information.

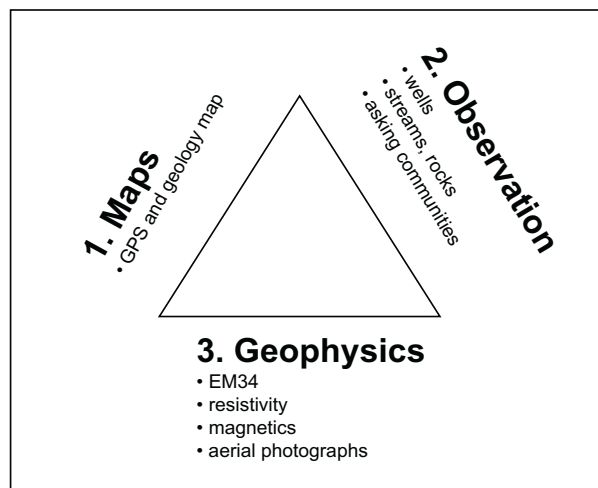

Figure 4.2 The geological triangulation method.

- Geophysics. Geophysical surveys can be undertaken at sites based upon geological observations made within the village. The type of geophysical survey depends on the rock types present. The survey results should support the observation data, confirming the type of rock present. The survey results can then be collated with observed data to identify targets for boreholes or wells (see Chapter 4.3).

4.2 COMMUNITY DISCUSSIONS AND VILLAGE OBSERVATION

Tapping into the experience and knowledge of local communities plays an integral part in understanding the geology of a village. Community members have the greatest experience of the surrounding environment and the history of water development within their village. Discussions and observations at a village are usually to help answer the following questions: what is the rock type at the village? Has there been any exploration there before? Where are there current wet and dry water sources? Useful people to meet are any well diggers, women who fetch water and children.

What is the rock type of the village?

- Prepare by looking at the geological map for the area and what sorts of rock are likely to be there.
- In discussion find out where the rocks in the area are exposed (children often know the best)
- Visit any wells that have been dug and identify the soil rock profile with depth. Examine a sample of the deepest rock. Find from well diggers how hard the rock is.
- Visit any borehole sites (failed or working) and look for any rock chippings from drilling.
- Visit places where rocks are exposed – make sure they are the true bedrock and not just rocks that have been carried into the area. Good places to look are river valleys and small hills (see Figure 4.3).
- Observe boulders in the village used for seats, grinding stones etc. and find out where they have come from.

Hints: concrete looks very much like sandstone; do not be fooled by rocks that have been brought into the area or washed down in rivers. Take samples where possible and get a second opinion.

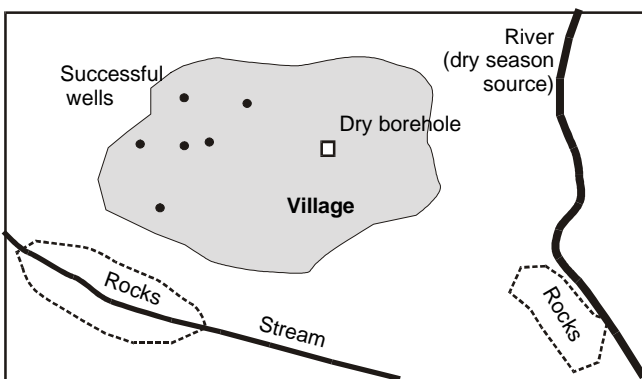

Figure 4.3 Places to visit on a reconnaissance visit to a community.

Where are there current wet and dry season sources?

- Prepare by looking at any old files, reports or databases from previous projects.
- Discuss with community members all sources of water within the village.
- Visit well sites, measure water levels and salt content of the water. Find out how much water is taken at different times of the year – particularly at the peak of the dry season, and in drought.
- Visit boreholes, discuss depth with community (e.g. number of rods used in its drilling, or lengths of screen and casing in its construction) and yield at different times of the year.
- Visit pond or river sources. Measure salt content of water. Discuss how many people use the source, at what time of year, how much and for what purpose.

This information should give some indication of the likelihood of groundwater in the area. If some wells and boreholes have considerable groundwater throughout the year, or pond sources have a high salt content and are sustainable throughout the year, then groundwater is likely to exist in the area.

What are the sources of pollution around the village?

Information should also be gathered on potential sources of pollution in and around the village. However, care and tact must always be used when discussing sources of pollution. Most water projects should have a sanitation component, with qualified staff and individual techniques to discuss sanitation. Things to look out for are:

- Type and location of on-site sanitation
- Burial grounds
- Cattle pens
- Market areas

One of the greatest barriers to tapping into this knowledge is language. Not only different spoken languages, but radically different ways of describing things. Those with experience of geology or water engineering describe rocks and water in a certain manner which is alien to most other people. It is always important to find an example of what is being described. It may take more time, but helps reduce uncertainty.

4.3 WHEN ARE GEOPHYSICAL TECHNIQUES REQUIRED?

Geophysical techniques are required if maps and observation alone do not give sufficient information to help site a successful well or borehole. They measure physical properties of rocks (hence the name ‘geophysics’). They do not directly detect the presence of water, and cannot be used as a failsafe method for siting wells and boreholes. All they do is help interpret what rocks are present in the area, and in some instances help locate where they may be more fractured.

There are many different geophysical techniques available and countless pieces of equipment. Many require sophisticated equipment or complex analysis and are therefore not appropriate for use in rural water supply programmes. A comprehensive list of different techniques is given in Table 4.1. The two most useful in the context of

rural water supply in sub-Saharan Africa are electrical resistivity and ground conductivity. Magnetic techniques are also sometimes useful. The working and analysis of these three methods using the most common equipment are described below.

Table 4.1 Summary of common geophysical techniques used in groundwater investigations (from MacDonald *et al.* 2000).

Geophysical technique	What it measures	Output	Approximate maximum depth of penetration	Comments
Frequency domain EM (FEM)	Apparent terrain electrical conductivity (calculated from the ratio of secondary to primary EM fields)	Single traverse lines or 2D contoured surfaces of bulk ground conductivity	50 m	Quick and easy method for determining changes in thickness of weathered zones or alluvium. Interpretation is non-unique and requires careful geological control. Can also be used in basement rocks to help identify fracture zones.
Transient EM (TEM)	Apparent electrical resistance of ground (calculated from the transient decay of induced secondary EM fields)	Output generally interpreted to give 1D resistivity profile	100 m	Better at locating targets through conductive overburden than FEM, also better depth of penetration. Expensive and difficult to operate.
Ground penetrating radar (GPR)	Reflections from boundaries between bodies of different dielectric constant	2D section showing time for EM waves to reach reflectors	10 m	Accurate method for determining thickness of sand and gravel. The technique will not penetrate clay, however, and has a depth of penetration of about 10 m in saturated sand or gravel.
Resistivity	Apparent electrical resistivity of ground	1-D vertical geoelectric section; more complex equipment gives 2-D or even 3-D geoelectric sections	50 m	Can locate changes in the weathered zone and differences in geology. Also useful for identifying thickness of sand or gravel within superficial deposits. Often used to calibrate EM surveys. Slow survey method and requires careful interpretation.
Seismic refraction	P-wave velocity through the ground	2-D vertical section of P-wave velocity	100 m	Can locate fracture zones in basement rock and also thickness of drift deposits. Not particularly suited to measuring variations in composition of drift. Fairly slow and difficult to interpret.
Magnetic	Intensity (and sometimes direction) of earth's magnetic field	Variations in the earth's magnetic field either along a traverse or on a contoured grid	30 m	Can locate magnetic bodies such as dykes or sills. Susceptible to noise from any metallic objects or power cables.
VLF (very low frequency)	Secondary magnetic fields induced in the ground by military communications transmitters	Single traverse lines, or 2D contoured surfaces.	40 m	Can locate vertical fracture zones and dykes within basement rocks or major aquifers

4.4 GROUND CONDUCTIVITY USING FEM

4.4.1 How ground conductivity instruments work

FEM methods measure the bulk electrical conductivity of the ground by passing an alternating electromagnetic field over and through the ground and measuring the secondary electromagnetic produced. Figure 4.4 illustrates the basic principles. The time varying electromagnetic field generated by the transmitter coil induces small currents in the earth. These currents generate a secondary electromagnetic field, which is sensed (along with the primary field) by the receiver coil. The ground conductivity (or apparent conductivity) is then calculated by assuming a linear relation between the ratio of secondary and primary fields). Over a sub-horizontally layered earth, the response will represent a weighted mean (related to depth) of the rocks within the range of investigation.

The coils can be orientated either vertically or horizontally, as shown in Figure 4.5. Different orientation changes the direction of the inducing field and what the instrument is sensitive to. For vertical coils the reading gives a good estimate of the electrical conductivity (in mS/m – sometimes quoted as mmhos/m). The maximum contribution is from the ground surface, and the response reduces with depth; the average depth of penetration is about 0.5 - 0.7 x the coil spacing. Horizontal coils do not give a good estimate of electrical conductivity beyond about 30 mS/m. In fact the highest reading the horizontal coils can give is 65 mS/m. However, when the instrument

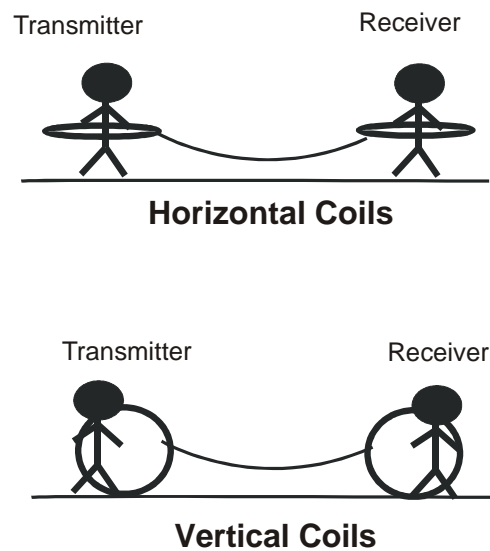

Figure 4.5 The different possible orientations of FEM equipment.

is used with horizontal coils it is sensitive to vertical conductors, such as vertical fractures - often good targets for groundwater. When passing over a vertical anomaly a negative response is given. Sometimes this can actually give readings of less than zero, which at first can be rather confusing!

When the coils are horizontal, the readings are very sensitive to misalignment of the coils. With vertical coils the instrument is not sensitive to misalignment of the coils,

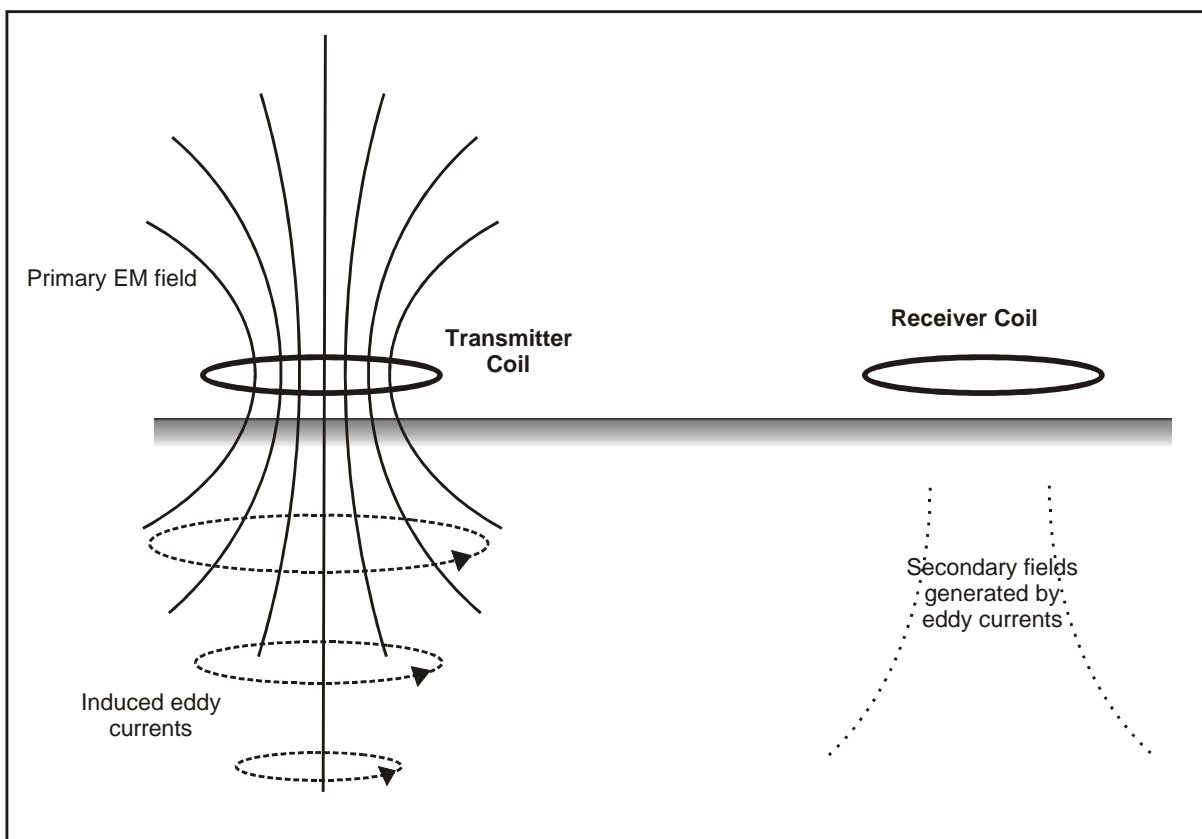

Figure 4.4 How ground conductivity methods work.

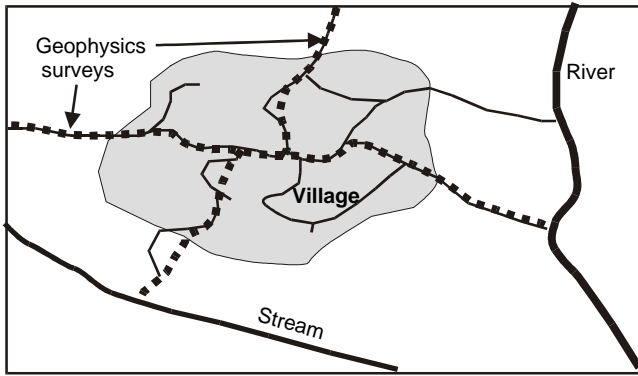

Figure 4.6 Choosing survey lines in a community.

but is rather more sensitive differences in intercoil spacings.

4.4.2 Carrying out a survey

General principles for carrying out a ground conductivity survey are outlined below. A more detailed account specifically for the EM34 instrument is given in the Appendix.

1. Walk round the village where the survey is to be carried out and try to locate good survey lines. Bear in mind where the community may want the borehole or well sited and where field geological information is (e.g. rock exposures or existing wells etc.). Two surveys roughly at right angles extending outside the village often provide the best information (Figure 4.6)
2. Find an area to set up the equipment free from significant influences such as power lines or metal roofs. Choose the appropriate coil separation (and frequency) for the survey. Generally a 20-m coil separation is most useful for reconnaissance. Carry out the daily checks on the equipment, such as battery and nulling. (The sheets in the Appendix explain how to take a reading with the EM34 instrument). Once the equipment is set up satisfactorily the survey can start.
3. Start at a noticeable feature (e.g. a large mango tree) at one end of a survey line. Always have the coils in the same order, for example with the receiver always trailing the transmitter – this avoids confusion over distances. All distance, comments and reading should be recorded from the receiver.
4. Roughly measure distances. The coil separation indicated by the instrument is usually a good enough measure. Make sure that noticeable features are recorded accurately at least every 40 m, so that any readings from the instrument can be pin pointed on the ground.
5. Keep a detailed notebook. Figure 4.7 shows an example of a page from a notebook. At the start of each survey general information should be given such as the date, location, surveyors, equipment and coil separation. The start of the survey should be carefully described. To record the readings the SDVHC system is very useful: this stands for **S**tation, **D**istance, **V**ertical coil reading, **H**orizontal coil readings and **C**omments. Make sure that any metal objects (such as tin roofs) or problems (such as misalignment of horizontal coils) are carefully recorded.

Figures 4.8 to 4.10 show the EM34 instrument being used in the field.

4.4.3 Interpreting FEM survey results (using the EM34 instrument)

Interpreting ground conductivity results depends on the geology and hydrogeological targets. In crystalline basement rocks (and volcanic rocks) the main targets are either the weathered zone, or deeper fractures. In sedimentary rocks (both consolidated and unconsolidated) the targets are generally sandstones and sometime fractures. Interpreting data relies on understanding the electrical properties of rocks and minerals. Several factors affect the electrical conductivity of the ground:

- The electrical conductivity of the rock minerals – generally very low
- The volume of water in the rock (porosity and saturation)
- The salt content of groundwater
- The amount of clay in the ground – clay is highly conductive.

It can be very difficult to distinguish a useful fresh groundwater resource from the presence of salty water or clayey rocks by the use of ground conductivity methods alone. This is why geological triangulation is so important – the geophysical data must be interpreted in the light of the geology that is thought to underlie the area. Figure 4.11 shows the electrical conductivity of common rock types.

Date: 12 Feb 2001
Village: Egori Ukpute 34.321°N 12.012°E
Surveyors: Bitrus Goyol
 Alan MacDonald

Starting at the large mango tree, roughly 1 km to the North of the village at the edge of the river.

Em34 - 20 m coil separation receiver trailing

S	D	V	H	C
1	0 m	312	33,4	Bearing 210 degs large mango tree
2	20 m	32.1	35.3	
3	40 m	34.3	32.2	ant hill left
4	60 m	34.1	34.6	H- coils uneven
5	80 m	32.2	32.2	dry borehole Right
6	100 m	32.3 311	32.2	
7	120 m	29.2	311	Bearing 260 degs
8	140 m	26.1	24.2	path left @ 145 m
9	160 m	23.2	22.1	
10	180 m	23.8	26.1	dry tree Right
11	200 m	19.2	20.2	
12	210 m	19.3	18.2	small kitchen left

Figure 4.7 Example of a notebook for a ground conductivity survey using EM34 equipment.



Figure 4.8 The EM34 equipment, comprising two coils, a connecting cable, transmitter and receiver.



Figure 4.9 The EM34 being used with the coils horizontal.



Figure 4.10 The EM34 with coils vertical. Note that the operator with the receiver is also taking the readings.

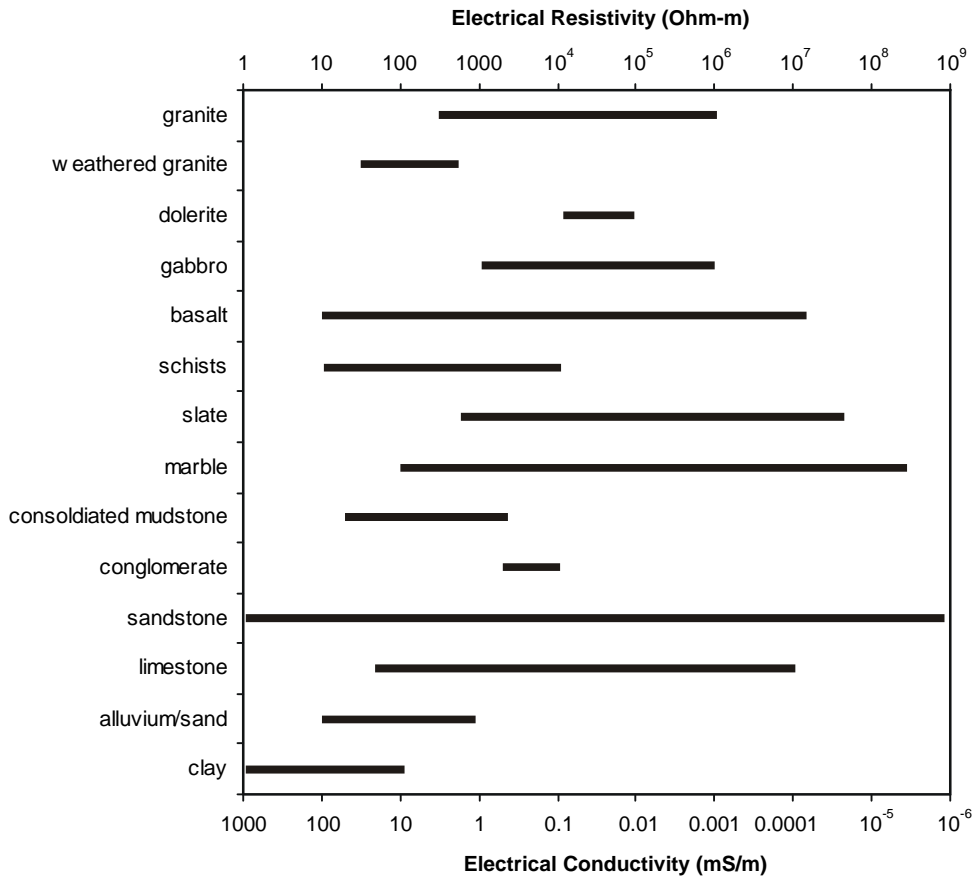

Figure 4.11 Resistivity and conductivity of common rock types.

To help interpret ground conductivity data many different case examples were examined of targets in basement and sedimentary rocks. These case studies were then generalised and modelled¹ to give typical responses for the main targets in basement and sedimentary rocks.

CRYSTALLINE BASEMENT ROCKS

Crystalline basement rocks and volcanic rocks generally do not conduct electricity (see Figure 4.11) because they have little primary porosity. In these rocks we are generally trying to identify thick weathering or deep fracture zones. Ground conductivity has proved very useful in these environments and there are many examples of their successful use (see further reading at the end of this chapter). Before using any of these interpretative techniques, geological triangulation must have established that the community is likely to be underlain by basement or volcanic rocks.

Identifying deep weathering

Figure 4.12 illustrates a common scenario in basement rocks. The main target for a well or borehole is where the weathered zone is thickest. The response of the EM34 instrument with 10, 20 and 40 m coil separations over this weathered pocket is also shown. Unweathered basement

rocks have low electrical conductivity (< 1mS/m) since they contain little water or clay. Weathered basement often has conductivity of about 10 mS/m since it comprises gravels with some clays. The soil zone has been modelled as 1 m thick with low conductivity – the most common scenario found in SSA. For completeness the models were rerun with a conductive soil (20 mS/m) which did not significantly affect the results.

Deeper weathering is clearly indicated by high conductivity measured by all coil separations and orientations. Therefore, the best target for a well or borehole in the weathered zone would be at distance 150 m where the weathering is thickest and the measurements highest. Some analysis methods suggest that the best target is where the horizontal coil readings become greater than the vertical coil readings. The modelling clearly shows that this does not need to be the case. In fact, readings with the horizontal coils are often uncertain because they are sensitive to errors in alignment of the coils – therefore more faith should be put in the vertical coil measurements.

Rarely is there opportunity to carry out surveys at all coil spacings and orientations. Which configuration gives the best information for changes in weathering of interest to the hydrogeologist – 10-50 m? Figure 4.13 shows conductivity measurements from different coil orientations over different thicknesses of weathering. Although deeper weathering is indicated by higher readings in all configurations, the various coil separations and orientations have different sensitivities to changes at depth. The 10-m coil separation is not good at differentiating differences in the thickness of weathering below about 10 m. The 40-m coil separation is good at differentiating deep changes in weathering, but not shallow changes. Therefore, the 20-m

¹ Modelling was carried out using EMIGMA™ - a 3D EM coupling package, and EMIXP™ a simple 1D EM package

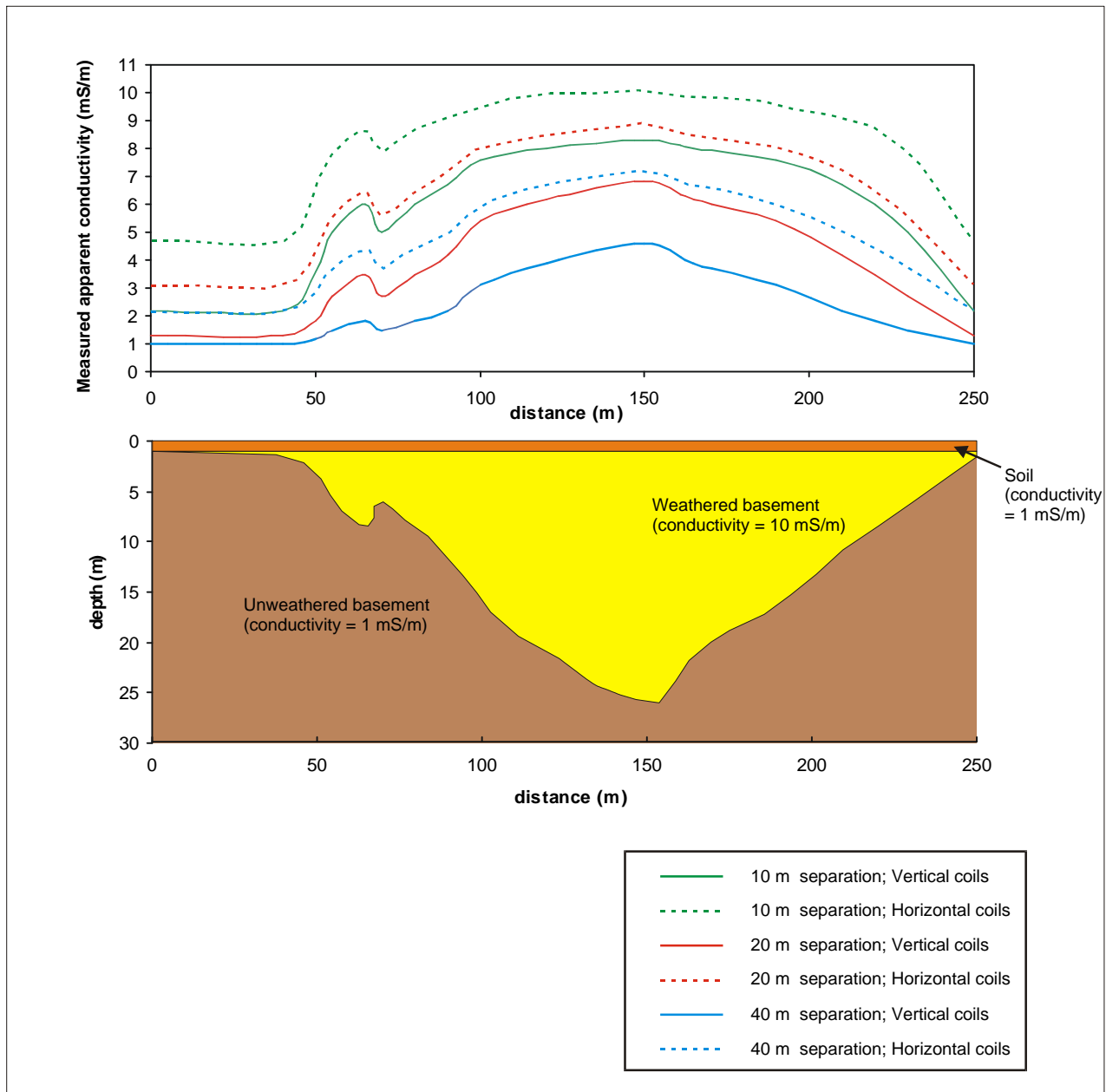

Figure 4.12 Ground conductivity measured using the EM34 instrument over a pocket of weathered basement rocks.

coil separation with vertical and horizontal coils is probably the best configuration for initial surveys, repeated with 40-m if time allows.

Box 4.1 Summary for surveys to identify deep weathering in basement.

Carry out a survey with 20-m coil separations using both the vertical and horizontal coil configurations.

If time permits, repeat with 40-m coil separations over areas with high readings.

Deeper weathering and therefore good targets for wells and boreholes are indicated by high readings in vertical and horizontal coils (around 10 mS/m).

Higher readings (20 mS/m and above) in valleys are probably due to clay development in the weathered zone in dambo like structures – these are not often good targets for wells and boreholes.

Horizontal coil readings are sensitive to misalignment of coils, therefore more faith should be placed in vertical coil readings.

Considerably higher readings in a basement area are often associated with surface clays, such as those found in dambos. These are generally in valleys and will give rise to high readings with 10 and 20-m coil separations. These are generally not great sites for wells and boreholes because of the swelling clay near to the surface. Comments in the geophysics notebook should help interpret high readings as dambos, since they are easily identified in the field. In a dambo ground conductivity may be greater than 30 mS/m, which is higher than would ever be measured in clay-free weathered basement.

Identifying fracture zones

The other main target in basement areas is fracture zones. These are deep fractures (generally greater than 20 m) associated with faults and tectonic movement. Fracture zones tend to be more conductive to electricity than the host crystalline rock since they contain water and also the

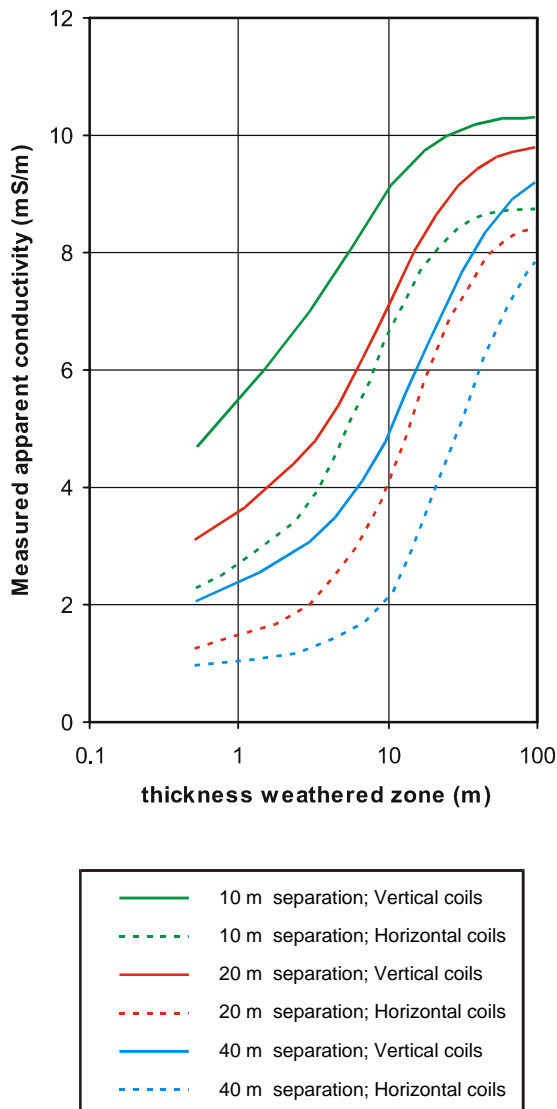

Figure 4.13 Apparent conductivity measured over increasing thicknesses of weathered basement using different coil spacings and orientations.

increased circulation of water has helped to weather the nearby rock to produce some clay. Fracture zones are more difficult to detect with geophysical equipment than changes in the thickness of the weathered zone. The response of fracture zones to electromagnetic methods is much more complex than the 1D response of changes in weathering. This is mainly because the width of the feature is of the same scale as the coil separation and because the fractures are often orientated horizontally.

Figure 4.14 shows modelled data for a single vertical fracture in basement rocks. This classic response is often quoted in text books. The vertical coils show very little response; the horizontal coils however show a marked negative anomaly centred over the fracture. This is confusing at first since the fracture zone actually has higher conductivity than the surrounding rocks. However, the equipment responds three-dimensionally to these complex shapes and the negative anomaly is a result of electromagnetic coupling between the inducing field and the conductive fracture.

More realistic fracture zones have also been modelled. These are made up of multiple fractures joined together

with electromagnetic induction between them. Even more complex anomalies can be encountered (Figure 4.15). Sometimes there are positive readings, sometimes negative. In our experience we have found the exact form of the anomaly unimportant for siting wells and boreholes. *Fractured bedrock can exist where the horizontal coils give a noisy profile.*

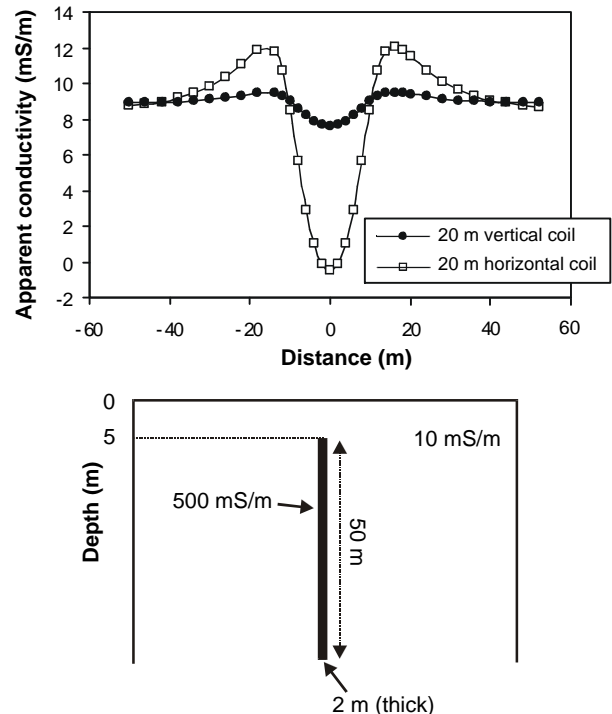

Figure 4.14 Response of the EM34 instrument over a single vertical conductor.

As discussed in the previous section, however, the horizontal coils can also give noisy profiles when misaligned. Therefore it is vital to carry out the survey carefully and record any problems in the field notebook. Then when analysing the data you can be confident that the horizontal coils anomalies are due to fractures.

Box 4.2 Summary of surveying for fracture zones in basement rocks.

Carry out a survey with 20-m coil separations using both the vertical and horizontal coil configurations

If time permits, repeat with 40-m coil separations over areas with noisy readings

Keep a careful notebook and ensure that any problems with horizontal coil orientation are noted

Fracture zones are identified as significant noisy readings with the horizontal coils; the vertical coils are generally insensitive to fractures.

Noisy readings can also be given by the misalignment of horizontal coils (e.g. when going up or down steep slopes) and significant metal (fences or metal roofs).

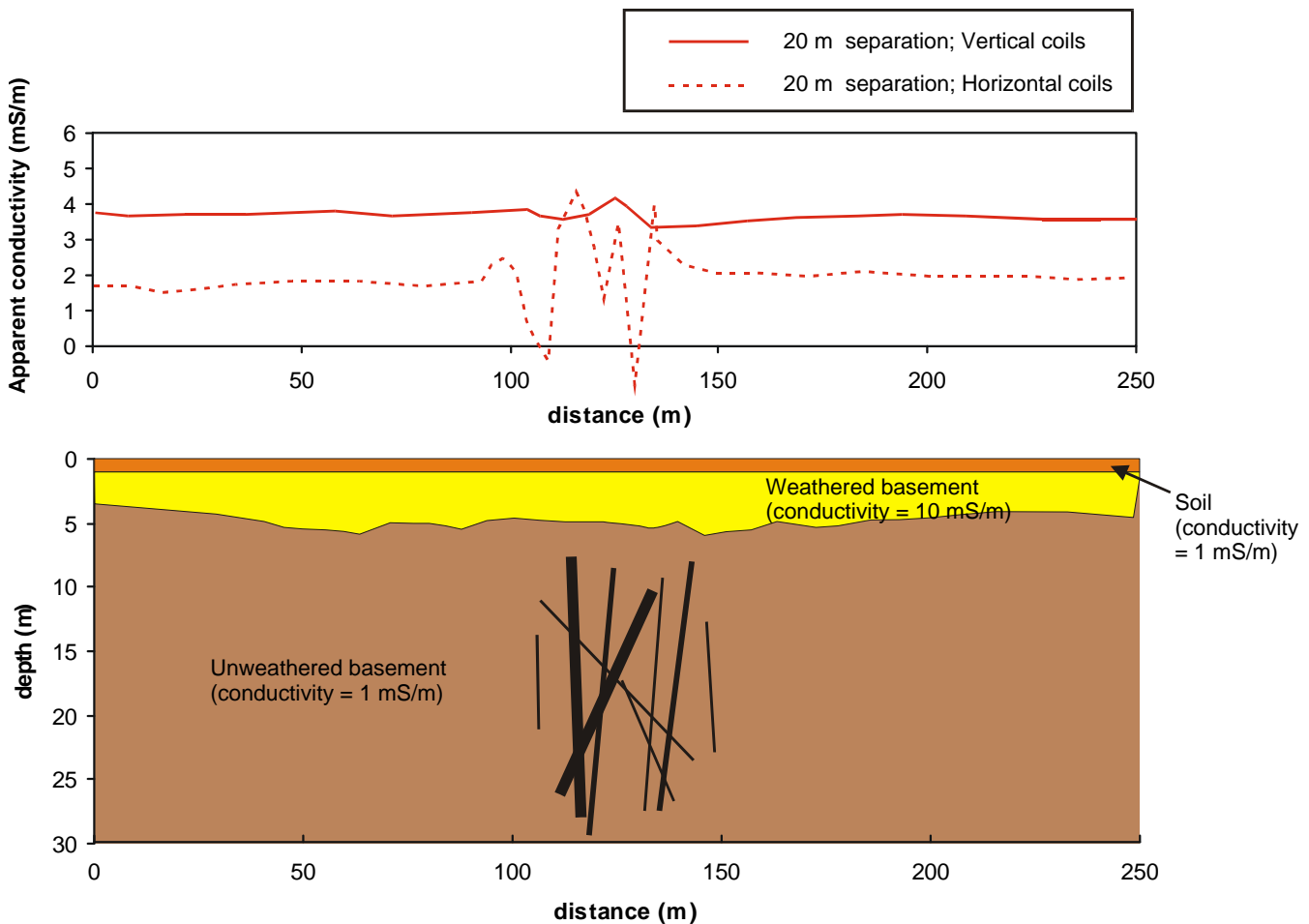

Figure 4.15 Schematic diagram showing the kind of response that is given by ground conductivity (using the EM34 instrument) over fracture zones in basement.

SEDIMENTARY ROCKS

Sedimentary rocks conduct electricity. Electricity can move through water in pore spaces in sands and sandstones and also along the surface of clay minerals. This ambiguity makes interpreting FEM data in sedimentary areas difficult. Good ground control is required to help interpret the data so that clay can be distinguished from saturated sandstone. The geological triangulation method described above forms a useful strategy for gathering ground control information. The different scenarios described below can be used for either consolidated or unconsolidated sedimentary areas.

Locating sands within clay

Sands and sandstones are generally much better targets for groundwater supply than clays and mudstones. Electrical methods can easily distinguish clays and mudstones from sands and sandstones: pure clays and mudstones tend to have much higher electrical conductivity. Therefore using a rapid survey method such as EM34 can help identify areas underlain by sandstone or sands. Figure 4.16 shows how a boundary between sandstone and mudstone can be mapped within a village. Pure sands and sandstones with little clay content should give electrical conductivity below about 20 mS/m. Only the vertical coil reading should be

compared, since horizontal coils are insensitive to changes in electrical conductivity at high conductivities.

It can be more difficult to distinguish sandstones from clays and mudstones when the sandstone layers are thin. The change can be noticeable if the sand is shallow, but may easily be missed in overall variations in ground conductivity. Undertaking surveys at different coil-spacings can help interpretation of the data. For example if the 10 m coil spacings indicated low conductivity, but the 40 m coil spacings high conductivity, this would suggest a shallow low conductivity (possibly sand) layer.

Identifying different types of mudstone

In chapter 2 we reported the results of some new research which indicated that groundwater may be found in certain types of mudstone. Where mudstones have been slightly metamorphosed, fractures (and therefore groundwater) are more likely. Soft mudstone contains very little usable groundwater. Soft mudstone can easily be distinguished from hard mudstone by measuring the electrical conductivity of the rocks. Soft mudstones have high conductivity, hard mudstones have low conductivity. The reason for these changes is the amount of smectite clay present. Table 4.2 gives typical electrical conductivities measured in various mudstones in Nigeria.

Table 4.2 Electrical conductivity of different mudstones measured in Nigeria.

Type of mudstone	Conductivity range (mS/m)	Mean Conductivity (mS/m)
Soft smectite mudstone (little groundwater)	80 - 270	140
Moderately hard mudstone (groundwater in large fracture zones)	40 - 110	50
Hard mudstone (groundwater generally available)	4 - 23	10

Identifying fractures

Large fracture zones, similar to those targeted in basement areas, can also be useful targets in sedimentary areas, particularly if the sandstones do not have significant primary porosity and permeability. Since sandstones generally have low conductivity they can be located in a similar way to that described for basement areas.

Fractures zones in mudstones behave in a different geophysical way to basement or sandstone. Mudstones are highly conductive, therefore there is not much contrast between the conductive faults and the host rock. In fact, in soft mudstone, fracture zones may actually be less

conductive to electricity than the host rock. In hard mudstones, fracture zones may not be distinguished at all using FEM. In moderately hard mudstones, fractures can be identified as negative anomalies, or a generally noisy profile using horizontal coils.

Box 4.3 Summary of surveying with ground conductivity in sedimentary environments.

Carry out a survey with 20-m coil separations using both the vertical and horizontal coil configurations.

Geological triangulation is vital to help interpret any data.

Use the vertical coil readings for comparisons of electrical conductivity, and horizontal coil measurements to look for fractures.

Sandstone (sand) can be distinguished from mudstone (clay) by low conductivity measurements (< 20 mS/m).

In a mudstone area, hard mudstone can be distinguished from soft mudstone by lower conductivity. If conductivity is very high (> 60 mS/m) then the mudstone is likely to be soft and of no use for groundwater.

Fractures in both sandstone and harder mudstone can be identified by noisy horizontal readings, and in particular negative anomalies.

If time permits, repeat with 40-m coil separations over areas with noisy readings.

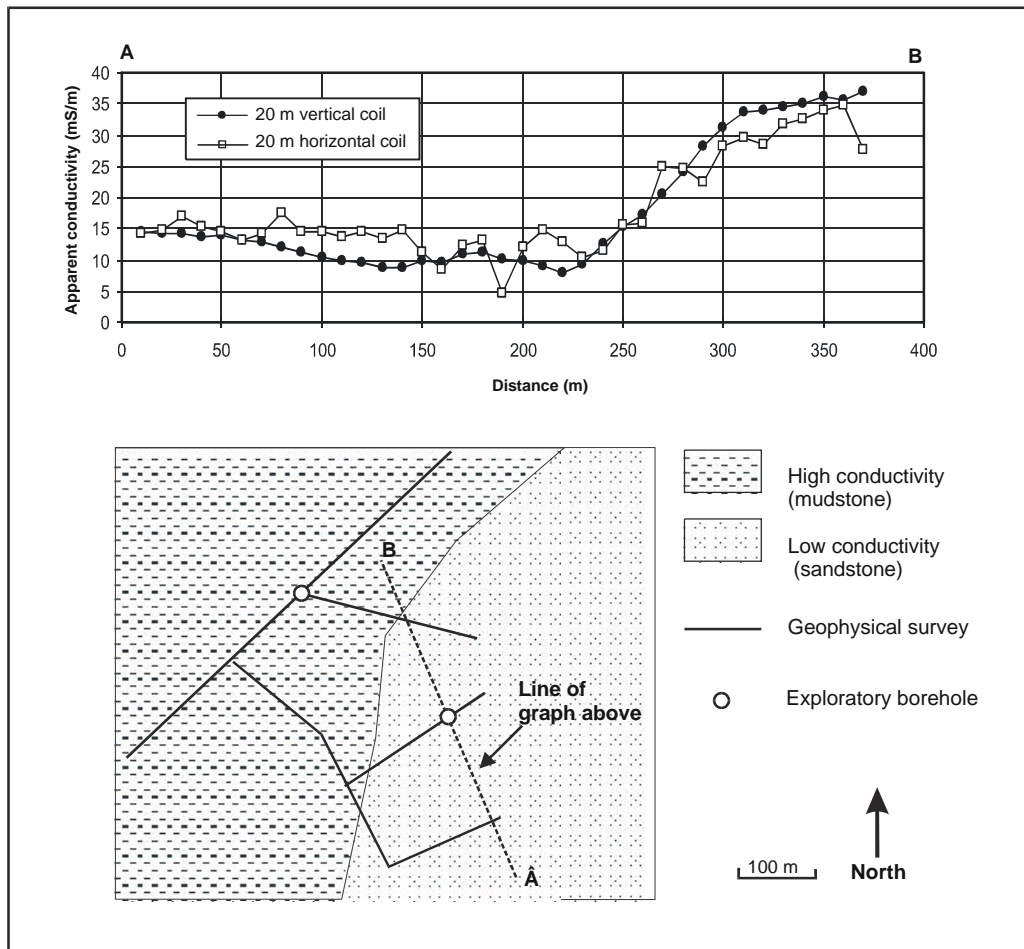

Figure 4.16 Using ground conductivity to map out the boundary between a sandstone and a mudstone in a village.

4.5 ELECTRICAL RESISTIVITY

4.5.1 How the resistivity method works

The resistivity technique is the longest established geophysical method used to site wells and boreholes in Africa. It has been used successfully for more than 50 years.

There are two main survey modes: profiling and depth sounding. Resistivity profiling is a relatively slow process and has largely been superseded by EM conductivity traversing for detecting lateral variations. Methods combining both profiling and depth sounding are now available and can give good insight into the geology. However, such surveys are complex and require specialist equipment and interpretation; for this reason they are not generally appropriate for small rural water supply projects. The most common resistivity survey method used in Africa is vertical electrical depth sounding (VES for short). This gives a one-dimensional profile of the resistivity beneath the midpoint of the survey. Electromagnetic methods (such as FEM described above) can give similar information when carried out at different coil spacings. However, since resistivity is so widely used it is discussed here.

Ground resistivity is measured by passing an electrical current through the ground and measuring the potential difference between two points. Ohms law is then used to calculate the resistance. The resistance is then multiplied by a geometric factor (normally called a K factor) to calculate resistivity. Resistivity is in fact the inverse of conductivity (see Box 4.4). Figure 4.11 shows the resistivity and associated conductivity values for common rock types. To carry out a depth sounding (VES), electrodes are expanded about a single point. When the electrode spacing is very wide, the electric currents pass deeper into the ground and are therefore measuring the resistance deeper into the ground. A depth sounding provides information only about one point (the midpoint of the survey). The technique assumes that there are no large lateral variations in the rock type. Table 4.3 shows the advantages and disadvantages of the VES resistivity method.

Table 4.3 Advantages and disadvantages of using resistivity VES.

<i>Advantages</i>	<i>Disadvantages</i>
Can identify layers of different resistivity (in other words changes with depth).	Highly susceptible to bad electrode connections.
Can penetrate deep into the ground.	Difficult to interpret
Not affected by tin roofs etc.	Laborious and slow.
	Can't locate vertical fracture zones
	Only takes a reading at one point

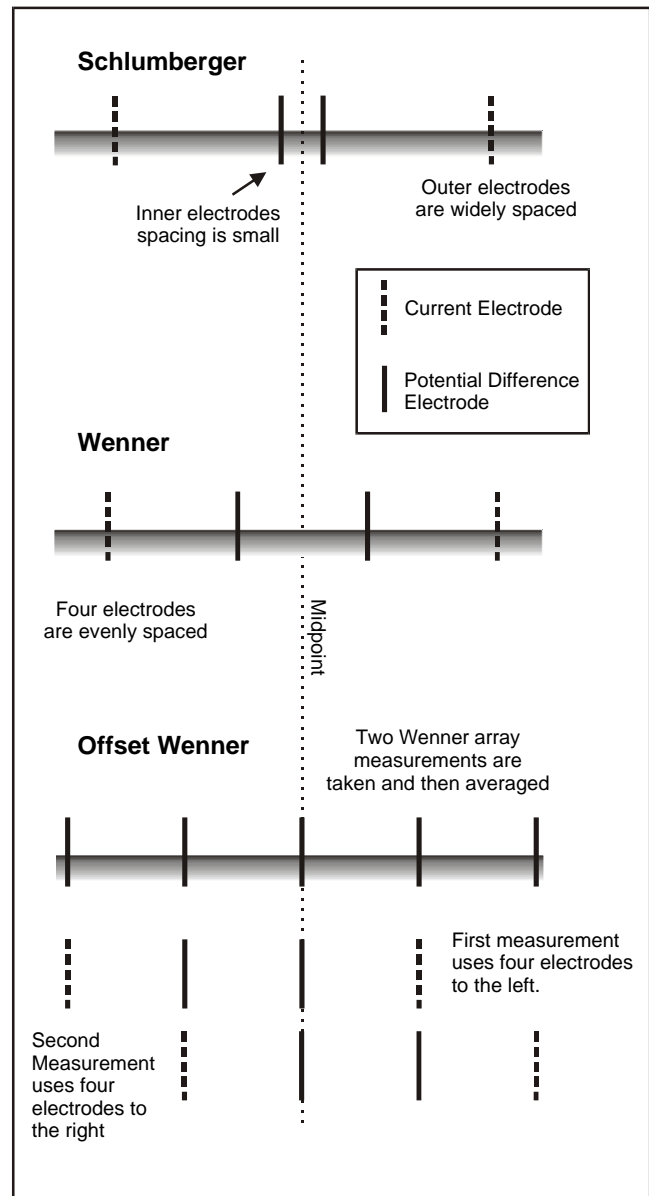

Figure 4.17 The three main electrode configurations for carrying out VES.

4.5.2 Carrying out a resistivity survey

There are different electrode configurations available for carrying out a VES. The three most common are Schlumberger, Wenner and Offset Wenner (see Figure 4.17). In all cases the electrodes are moved to set distances on either side of a midpoint. The Appendix has datasheets showing what the distances are, and the corresponding K values for the distances. Some tips for carrying out a survey are given below and illustrated in Figures 4.18 to 4.20).

1. Choose an area for the inner electrodes that looks fairly homogeneous.
2. Always make sure the battery is fully charged and carry a spare.
3. Make sure the electrodes are hammered well into the ground and water them. At large electrode spacings a salt solution can be used.

4. For small electrode spacings a small current should be used ($< 5 \text{ mA}$). Check that the resistivity is roughly the same at several current settings. If the current is too low, readings will vary.
5. At larger electrode spacings, higher currents are required since they have farther to travel.
6. Plotting the data as you go along allows you to see if any readings are anomalous. A resistivity curve should always look quite smooth.
7. As with all geophysical methods a notebook should be kept. If there are any doubts about readings, make sure this is clearly marked.



Figure 4.18 Equipment for carrying out resistivity surveys.



Figure 4.19 Electrodes have to be hammered in and sometimes watered to ensure good electrical contact with the ground.



Figure 4.20 The instrument stays at the midpoint and cables run out to either side.

Box 4.4 Resistivity and Conductivity

Resistivity is the inverse of conductivity – therefore high resistivity means low conductivity. Resistivity in ohm-m is related to conductivity (in mS/m) by the formulas:

$$\text{Resistivity} = 1000 / (\text{conductivity})$$

$$\text{Conductivity} = 1000 / (\text{resistivity})$$

4.5.3 Interpreting resistivity data

Resistivity data are interpreted by plotting the apparent resistivity against electrode spacing on a log-log scale. This should produce a smooth curve. Detailed quantitative interpretation can be carried out by computer using a variety of computer packages (such as Resixplus™) or using type curves. These are described in many text books and are not considered in detail here. However, a rough interpretation can be given by just looking at the shape of the apparent resistivity curve. For Offset Wenner and Wenner the curve can be interpreted directly, for a Schlumberger array, however, the curve will be in several segments. These can be combined into one smooth curve, by using the crossover points (readings taken with the same outer electrode spacing but different inner electrode spacing). Starting with the right-hand segment, move it up or down to match the cross over points of the segment to the left. Repeat the process (always moving the right-hand segment to meet the left-hand one) until you have one smooth curve.

Figure 4.21 shows some common curves for basement areas and a rough interpretation beside them. For basement areas, the main target is the low resistivity weathered zone. Therefore if the curve shows low resistivity at large electrode spacings, then the weathered zone is likely to be deep.

Figure 4.22 shows some common curves for sedimentary areas. In an area with sandstone and mudstone, the main target will usually be the sandstones. Sandstones (or sands) at depth will be indicated by higher

Box 4.5 Summary of resistivity VES.

Resistivity involves passing electrical currents into the ground through electrodes and measuring the resistance.

Electrodes are expanded about a midpoint to allow the current to penetrate deeper into the ground.

There are different electrode arrays – the most common are Schlumberger, Wenner and Offset Wenner.

Resistivity is highly susceptible to errors in arid areas – mainly due to poor electrode contacts with the ground.

Resistivity data can be interpreted quantitatively on computer or using type curves.

Rough qualitative interpretation can be given by looking at the shape of the apparent resistivity curve produced from the data.

Much of the same information can be given by repeating electromagnetic surveys (using EM34 equipment) with different coil spacings.

resistivity measurements at the wider electrode spacings; mudstones or clays will be indicated by low resistivity at large electrode spacings. If trying to differentiate hard mudstone from soft mudstone, then lower resistivity readings (sometimes less than 10 ohm-m) will generally be by soft mudstones, which will not usually contain water.

4.6 FURTHER TECHNIQUES

4.6.1 Magnetic methods

Magnetic methods in geophysical exploration involve measuring the intensity of the earth's magnetic field. Variations in the magnetic field are complex and often highly localised, due to differences in the magnetic properties of rocks near to the surface. This makes the technique useful and sensitive for identifying certain types of rocks, but can also make the data quite difficult to analyse.

The earth's main magnetic field originates from electrical currents in the liquid outer core. This magnetic field can be approximated by a dipole (bar magnet) located at the earth's centre and inclined at 11° to the spin axis. Magnetic materials can cause localised anomalies in the earth's magnetic field. There are many different forms of magnetisation but generally the most significant for geophysical surveys are ferrimagnetic and ferromagnetic. Ferromagnetic materials are strongly magnetic. Although they do not occur naturally, such materials are in common usage (e.g. steel in bridges, vehicles etc.) and can give large anomalies on surveys. Some rock minerals are also magnetic (known as ferrimagnetic), e.g. magnetite, maghaemite and pyrrhotite. When these are contained in rocks in sufficient quantities, they can cause measurable anomalies in the earth's magnetic field. In general sedimentary rocks have the lowest magnetic susceptibility; and basic igneous rocks the highest.

Magnetic methods are only useful if igneous rocks need to be identified. They can be useful for locating dykes (in some environments to avoid drilling in them and others, such as mudstones, to target them for drilling). Other uses can be to identify the extent of lava flows in volcanic rocks.

Magnetic surveys are relatively simple to carry out. Modern proton precessor magnetometers are easy to use and 5-10 km of survey can be carried out in one day. The data are plotted on graph paper. Any significant anomalies are either due to the presence of metal or igneous rocks. A careful record must be kept in a field notebook of any metal in a 50 m radius, such as metal roofs, cars, bridges etc. This allows the data to be analysed confidently.

4.6.2 Aerial Photographs

Aerial photographs can be very useful for identifying local geological conditions around a village or community. They are interpreted with the use of a stereoscope which gives a three dimensional picture of the ground at a scale of anything from 1:5000 to 1:24 000. They are often excellent for identifying fracture zones, which appear as subtle linear features. Changes in geology can also be often inferred

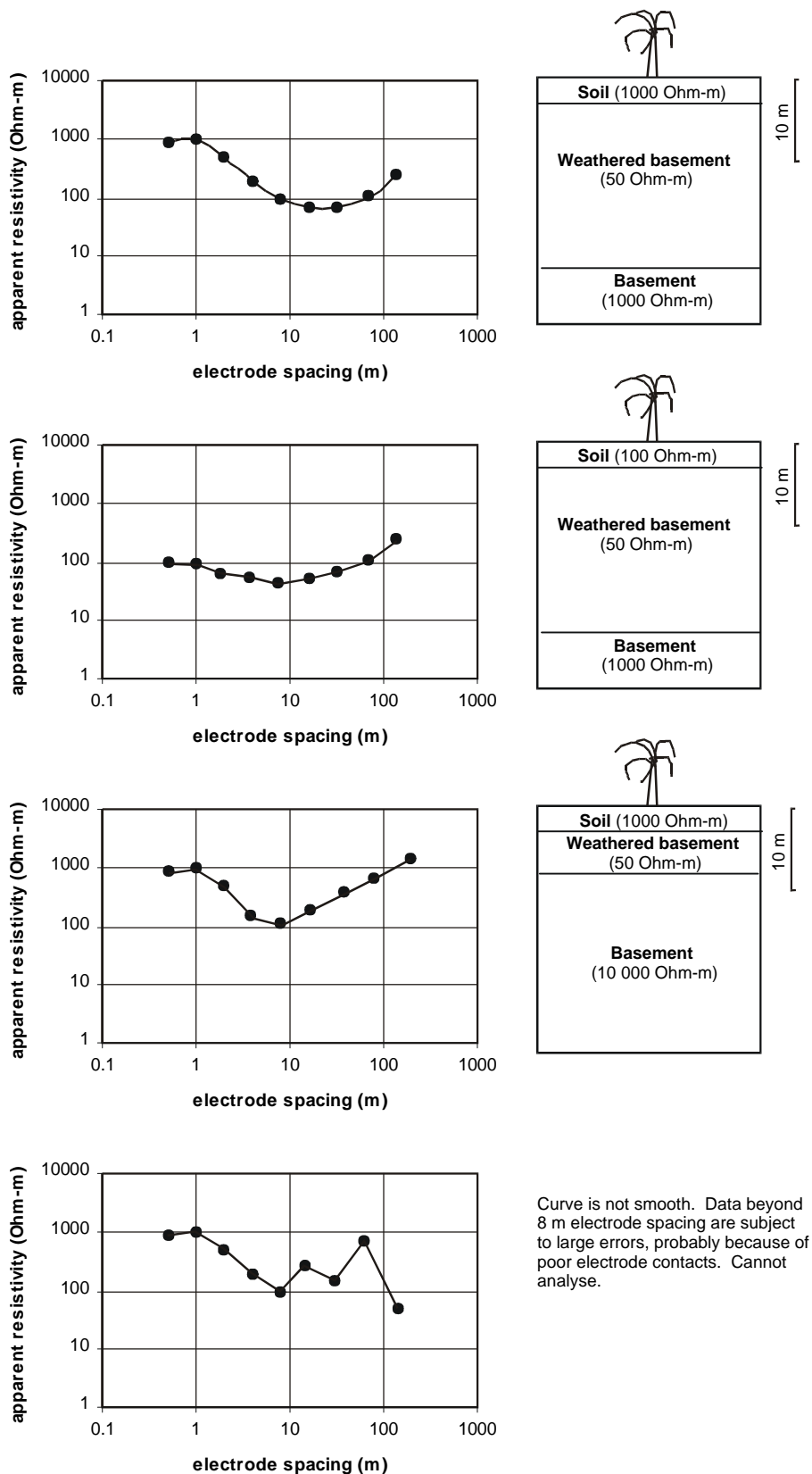

Figure 4.21 Common resistivity curves and their interpretation for basement areas

from the image. However, aerial photographs are often very difficult to get hold of in Africa. Even if they are available, they are often viewed as a security risk and not sold.

FURTHER READING

Textbooks

MILSOM, J. 1996. Field geophysics (2nd Edition). The Geological Field Guide Series, John Wiley & Sons, Chichester.

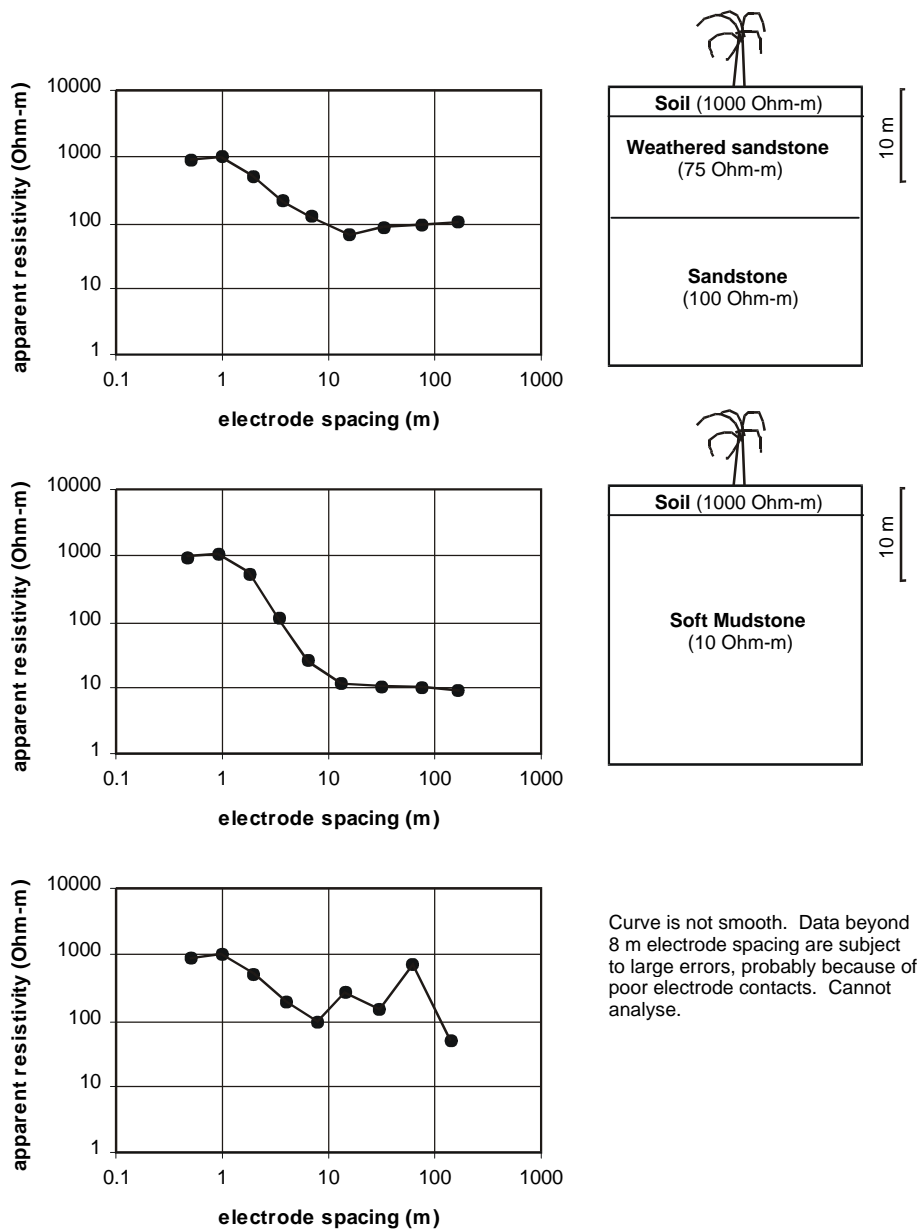

Figure 4.22 Simple resistivity curves and a rough interpretation for sedimentary areas.

REYNOLDS, J M. 1997. An introduction to applied and environmental geophysics. John Wiley & Sons, Chichester.

TELFORD, W M, GELDART, L P. AND SHERIFF, R E. 1990. Applied geophysics. Cambridge University Press, Cambridge, U.K., 770pp

Papers with good examples

BARKER, R D, WHITE, C C, AND HOUSTON, J F T. 1992. Borehole siting in an African accelerated drought relief project. In: Wright, E P, Burgess, W G (eds.), The Hydrogeology of Crystalline Basement Aquifers in Africa. Geological Society London Special Publication, 66, 183-201.

BEESON, S AND JONES, C R C. 1988. The combined EMT/VES geophysical method for siting boreholes. Ground Water, 26, 54-63

CARRUTHERS, R M AND SMITH, I F. 1992. The use of ground electrical methods for siting water supply boreholes in shallow crystalline basement terrains. In: Wright, E P and Burgess, W G

(eds.), The Hydrogeology of Crystalline Basement Aquifers in Africa. Geological Society London Special Publications, 66, 203-220.

MACDONALD, A M, DAVIES, J AND PEART, R J. 2001. Geophysical methods for locating groundwater in low permeability sedimentary rocks: examples from southeast Nigeria. Journal of African Earth Sciences, 32, 1-17.

5 Gathering information during drilling

If the results of reconnaissance and geophysical surveys have been favourable, drilling a borehole or digging a well can get underway. This provides an invaluable opportunity to actually observe what the rocks are like under a community. For surprisingly little effort or expense, information can be gathered on the location and nature of the water producing horizons.

Where the water table is shallow, and the material soft, communities can dig wells. These wells provide limited geological data on the shallow weathered zone. More detailed geological and hydrogeological data can be obtained during borehole drilling, and can show the distribution of weathered, non-weathered and fractured rocks at greater depths, and groundwater occurrence within them. Much useful information can be obtained from drilling during ongoing rural water supply projects, without the need for purpose-drilled exploration boreholes. This chapter describes some simple techniques for collecting data.

5.1 WHAT ARE BOREHOLES AND WELLS?

A borehole is a narrow-diameter tube drilled into the ground at a controlled angle (usually vertical) by mechanical means. Boreholes for rural water supply are generally drilled to a depth of between 20 and 100 m, although in some situations where the aquifers are very shallow or very deep they can lie outside this range. The basic parts of a typical borehole drilled for groundwater abstraction are shown in Figure 5.1.

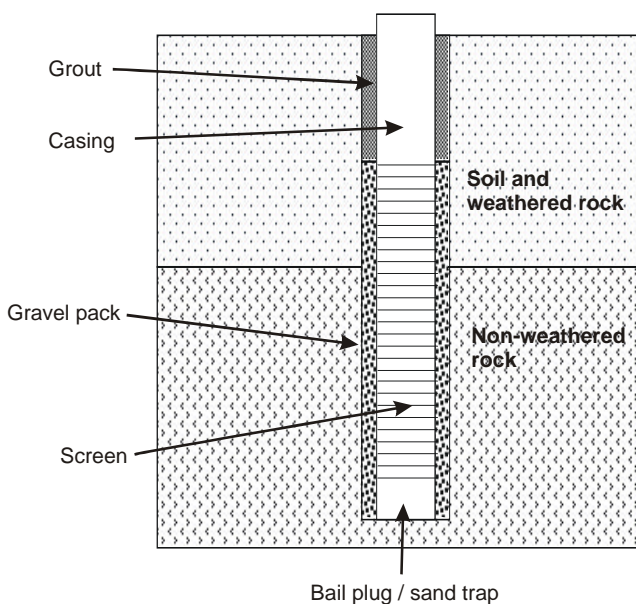

Figure 5.1 Component parts of a typical borehole.

A hand-dug well (as the name suggests) is constructed by hand. Typically, they are 1 - 2 m in diameter and from 10 to 20 m deep (although they have been constructed to over 100 m!). They tap shallow groundwater and have a large volume to allow the storage of several cubic metres of water. The basic construction of a hand-dug well is shown in Figure 5.2.

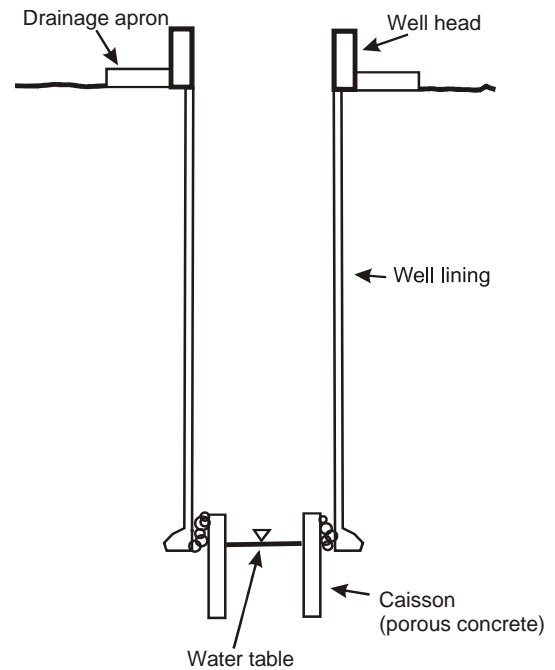

Figure 5.2 A typical hand-dug well.

Boreholes are best used where the target for groundwater is thought to be deep and the rocks hard. Hand-dug wells can be used only if the water-bearing rocks are shallow and the rocks soft enough to excavate with simple hand tools, or with the help of pneumatic hammers.

The construction of hand-dug wells is generally well understood by those involved in community water supply. However, the drilling of boreholes is often thought of as mysterious. To unravel some of this mystery a brief introduction is given below.

5.2 DRILLING METHODS AND EQUIPMENT

A drilling rig is a crane with a motor and a mast equipped with the necessary cables and/or slides to allow for the lift, fall and rotation of a drill string for the purpose of drilling a borehole. The drilling rig must have a mechanism to remove drilled rock cuttings during and/or between periods of drilling.

Various borehole drilling methods have developed because geological conditions are diverse, ranging from hard rock, such as granite and gneiss, to completely

Table 5.1 Summary of drilling methods and their applicability to different environments.

Drilling Methods	Formations to which method is best suited	Water table depth (m below ground)	Usual maximum depth (m)	Usual diameter range (mm)	Usual casing material	Remarks
Hand auger	Clay, silt, sand and gravel (particle size <20 mm)	2-9	10	50-200	Steel and PVC	Effective in clays and silts, casing needed in collapsing sand formations.
Power auger	Clay, silt, sand and gravel (particle size <50 mm)	2-15	25	150-900	Steel and PVC	As above. Two systems using solid-stem or hollow stem continuous flight auger drilling are used.
Driven boreholes including hand flap method	Clay, silt, sand and gravel (particle size <50 mm)	2-5	15	30-100	Steel and PVC	Limited to shallow water table, no large gravel.
Jetted boreholes including water/mud flush methods	Sand, silt and gravels (particle size <20 mm)	2-5	15	40-80	Steel and PVC	As above except in Bangladesh where boreholes drilled to 100m+ in areas where no large gravel found.
Drilled boreholes cable tool percussion	Unconsolidated to consolidated medium hard and hard rock	Any depth	450	100-610	Steel, PVC or glass reinforced plastic	Effective for water exploration. Casing required in loose formations.
Drilled boreholes rotary-direct circulation	Silt, sand and gravel (particle size < 20 mm); soft to hard consolidated rock	Any depth	450	110-450	Steel, PVC, or glass reinforced plastic	Fastest method for all but hard rocks. Casing usually not required during drill except near surface temporary pipe.
Drilled boreholes rotary-reverse circulation	Silt, sand, gravel and cobbles	2-10	120	400-1200	Steel, PVC, or glass reinforced plastic	Effective for unconsolidated sediments with shallow water tables. Boreholes typically large diameter and gravel-packed. Needs large volumes of water for drilling.
Drilled boreholes-rotary-air percussion	Soft to very hard consolidated rock	Any depth	600	110-500	Steel, PVC, or glass reinforced plastic	Very fast drilling. Combines rotary and percussion methods (air drilling) cuttings removed by air. Economical for deep water boreholes especially in basement hard rock.

unconsolidated sediments, such as sand and gravel, or weathered rock. Particular drilling methods have become dominant in certain areas because they are most effective for the local aquifers. The major water well drilling methods are summarised in Table 5.1.

The main drilling systems used in sub-Saharan Africa are:

- Cable Tool Percussion;
- Direct Rotary Air/Mud-flush;
- Rotary Down the hole Hammer Air-flush (DHD).

The Appendix gives detailed descriptions of these different methods and also the construction of hand-dug wells.

The capacity of a drilling rig depends on its lifting ability and the amount of torque that can be applied to the drilling string. The maximum drill rod and casing/screen carrying capacity of the drilling rig is limited by the length of travel along the mast. The width of the drill table opening limits the range of drilling bit and casing/screen

diameters that can be handled with safety. The choice of drilling rig for a particular job should be controlled by:

- the geological conditions;
- the budget of the project;
- the maximum depth of borehole hole to be drilled, plus an additional 25%;
- the types and dimensions (internal and external) of casing and screen to be used;
- the depth to water table;
- whether a gravel pack or formation stabiliser is required;
- the accessibility of the borehole drilling sites.

A number of texts describe drilling methods and equipment in detail, these are listed at the end of the chapter.

Should the borehole be considered suitable for equipping with a hand pump, the productive parts of the borehole may be screened and the rest of the borehole cased. Screen acts as a formation stabiliser in loose

weathered materials, as a filtration device to prevent loose weathered material from entering the borehole where it can block the pump, and as protection from larger lumps of rock which may fall from the borehole walls and damage the pump. In certain aquifer formations, such as hard fractured granite, a formation stabiliser and filter may not be needed.

A 2 – 4 mm washed gravel pack is usually emplaced around the casing and screen to the full length of the screen. The gravel in the borehole acts as a formation stabiliser in loose weathered materials, although as noted above, it may not be necessary to use a formation stabiliser in all aquifer formations. Coarse sand and gravel packs also act as a borehole filter.

Following construction and emplacement of casing, screen and gravel pack, an air line is inserted to the base of the borehole and compressed air used to lift water to the surface and remove sediment from the screen and fine material from the gravel pack and surrounding aquifer formation. The borehole is air-lifted for a period of one hour or until the water produced is considered clean. While this operation removes a certain amount of sediment from the borehole, a full air development procedure involves moving the air line up and down the borehole so that all levels of the screen are equally developed. Additional gravel is emplaced as required at the top of the borehole following any consolidation during airlifting.

A clay or grout seal is then put at the top of the gravel and the space then back filled. A good cement seal must be placed around the top of the borehole to stop surface water flowing down the sides of the borehole.

5.3 DRILLING AND SAMPLING PROCEDURES

Drilling and constructing a borehole requires various procedures: drilling; installing casing and screen; placing a filter pack (if required); grouting to provide sanitary

protection; and developing the borehole to ensure sand free operation at maximum yield.

There are usually a large number of people present on a drilling site. The tasks of the people involved in the drilling and sampling operation should be clearly defined, and care should be taken to make the site safe for everyone present. Members of the public should be kept at a safe distance from the drilling operation and any support vehicles with heavy machinery (see Figure 5.3). Particular care should be taken to keep children away from potentially dangerous areas, as they are usually especially curious about the drilling operation. An area for sample analysis should be set up next to but separate from the drilling operations.

The teams who will carry out the work, and their responsibilities, are as follows.

The **driller and crew**, as well as carrying out the drilling, should mark up the drill pipes with sampling points at regular intervals (specified by the hydrogeologist), and make sure that the marks are visible throughout drilling, to allow accurate sampling and measurement of penetration rates. The driller should have all the necessary equipment on site before drilling begins, including fuel, oil, water, casing, screen, and gravel pack. One of the drillers should be responsible for collecting representative rock samples at the specified intervals, usually in a bucket, and carrying them to the hydrogeologist.

The **hydrogeologist** should specify the sampling intervals and inform the driller so that the drill pipes can be marked at the required intervals. He should check that all the necessary equipment is on site before drilling begins, both for borehole drilling construction and for data collection and analysis (see below for a list of recommended equipment). Together with an **assistant or technician**, the hydrogeologist is responsible for washing and logging the rock samples, recording drill penetration rates and water



Figure 5.3 Community members standing too close to a drilling rig for safety.

strikes, measuring water flow rates and checking that the rock samples are being collected accurately. These tasks can be divided up as necessary.

The following list briefly sets out the activities which should take place on site to ensure effective borehole construction and data collection. It should act as a general checklist. A more detailed description of data collection and analysis techniques is given in the next section.

Before drilling starts:

- the rig should be adequately stabilised, for safety;
- the rig mast should be vertical, to make sure the borehole is vertically drilled;
- the drill pipes should be marked at regular intervals;
- all necessary equipment, for borehole drilling and construction and for data collection and analysis, should be present on site.

During drilling:

- a log book should be kept with notes of drilling activities and data collected;
- the borehole should be flushed clear of cuttings at each sampling interval and drill penetration should be stopped, to allow accurate sample collection;
- washing and logging of rock chip samples should be done during the times when drill pipe is being added;
- information on drill penetration rates, breaks or irregularities in drilling (reported by the driller), water strikes, water flows and dust production should be noted throughout drilling;
- the conductivity of borehole water should be

measured at regular intervals.

After drilling:

- the borehole should be thoroughly cleaned before the drill pipes are withdrawn;
- the final drilled depth of borehole should be measured with a plumb line and measuring tape;
- rock sample logging should be completed;
- the water level in the borehole should be measured;
- a pre-construction bail test should be carried out on the new borehole to indicate the borehole potential (see Chapter 6);
- if down-hole geophysical logging is to be carried out, it should be done before casing and screen are installed;
- the borehole configuration should be designed (using the information collected during drilling);
- if required, casing and screen should be carefully placed in the borehole so that the lengths of screen are set next to the water-producing horizons;
- the completed depth of the borehole should be measured;
- if required, the gravel pack should be properly washed and installed;
- the borehole should be cleaned and developed so that no sand is produced during pumping;
- if the gravel pack has settled during borehole development it should be topped up;
- the top of the borehole above the gravel pack should be grouted to form a sanitary seal;
- after water levels in the borehole have been given

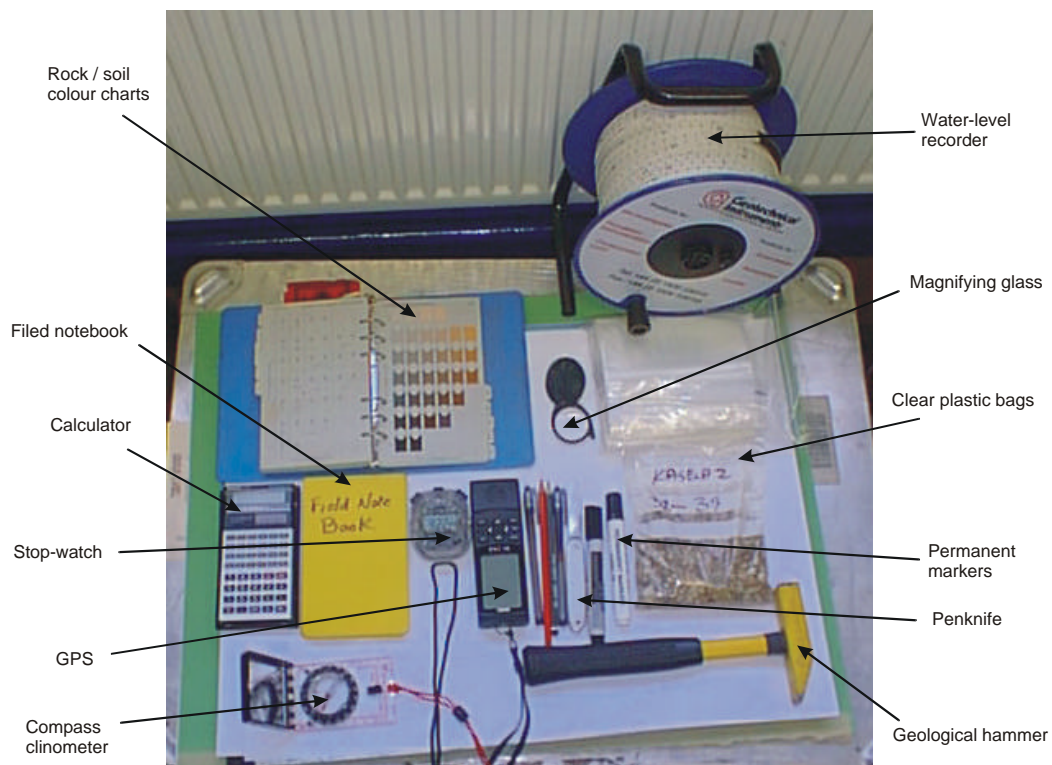

Figure 5.4 Equipment required for collecting and analysing data during drilling.

time to recover from drilling, they should be measured again;

- a post-construction bail test should be carried out to show the final borehole potential and test whether the borehole has been properly developed;
- a water sample should be taken for more detailed quality analysis;
- the top of the borehole should be adequately protected with a lockable metal cap if possible;
- issue a borehole completion certificate.

5.4 DATA COLLECTION DURING DRILLING

The main aim of data collection during borehole drilling is to identify water production zones in the geological sequence. This requires more information than is normally included on a borehole completion certificate. The collection of information during drilling is the only way to find out what is beneath the ground surface. The importance and methods of data collection during drilling are described in detail in Stone (1999). The following describes a list of useful equipment, which information should be collected, why it is important and techniques for

data collection and analysis.

5.4.1 Equipment required

Some basic equipment is useful for collecting and analysing data from drilling (Figure 5.4). The combined list costs much less than drilling one borehole (roughly one fifth) and much of it will last for many years, the consumable items are very cheap – plastic bags and pens. A camera can also be useful. Photographs of chip samples, or even the drilling process can be a useful record and help to jog memories about various sites.

5.4.2 Techniques for collecting data during drilling

Data from drilling can be divided into two types: those collected from the drilling process and those from analysis of rock samples. As with all fieldwork it is most important to keep a clear notebook. Figure 5.5 shows an example of a notebook for gathering data during drilling.

Drilling and construction parameters

The following information should be recorded for each borehole, using notes, diagrams and photographs as necessary.

- the main drilling rig type and drill bit;
- the flushing medium (air, mud or foam);
- details of additional equipment used (e.g. air compressor);
- the borehole dimensions (drilled depth and diameter, and completed depth after construction);
- the type and details (lengths and depths) of casing and screen installed.

Penetration logs

The drilling rate is monitored by recording the time taken to drill a specified interval, usually every 1.0 m (see Figure 5.5). Measurements are made using a stopwatch, and plotted on a graph (see Figure 5.10 for an example of a penetration log). The speed of drilling reflects the relative hardness of the rock horizons penetrated, and can be an important indicator of water-bearing horizons. Weathered zones, which often contain groundwater, are generally soft, while the boundary between the weathered zone and harder bedrock, also a potentially water-bearing zone, may be marked by a change to a slower penetration rate. Breaks in drilling may indicate soft horizons or fracture zones.

Dust production

When using down the hole hammer drilling, the amount of dust produced at each depth interval should be recorded. This is a subjective measurement (it is impossible to measure the amount of dust produced accurately) but it is a good basic indicator of whether water is present. In zones of water flow, very little or no dust is produced during drilling, while in dry zones there is usually plenty of dust.

Date: 11 Nov2001		
Village: Egori Ukpute 34.321°N 12.012°E		
Filedworkers: Alan MacDonald		
Driller: Peter Rastell		
8 inch rock roller		
6 inch hammer		
DTH - DandoGeoteck 5 - airflush		
Depth	Time	Comments
Rod 1		
0- 0.5 m	35 s	
0.5 - 1 m	49 s	
1 - 1.5 m	56 s	jerky
1.5 - 2 m	35 s	
2 - 2.5 m	1 min 20s	
2.5 - 3 m	4 min 34 s	
Rod2		
3 - 3.5 m	1 min 10 s	Change to DTH
3.5 - 4 m	1 min 30 s	
4 - 4.5 m	50 s	Dusty
4.5 - 5 m	1 min 40 s	
5 m - 5.5 m	1 min 12 s	
5.5 - 6 m	3 min 4 s	Damp

Figure 5.5 Example of field notebook for assessing drilling conditions.

Water strikes

Recording the depths of water strikes during drilling gives direct evidence of the locations of water-flow zones. The presence of zones where the rock chippings are damp should also be recorded (although this is only possible when using air-flush methods, not mud or foam-flush) as well as obvious water strikes.

Water flow rates

The water blown out of the borehole during air-flush drilling can give an indication of borehole yield. A basic measurement of water flow rate can be made by channelling the water away from the borehole through a pipe into a bucket of known volume and measuring the time taken to fill the bucket in litres per second (see chapter 6). This can be done at regular intervals throughout drilling.

Water-levels

Once the borehole is drilled, the water level in the borehole should be measured using a dipper (see Figure 5.4). This should be done immediately following drilling, and also once water levels in the borehole have recovered.

Water quality

Measurements of temperature, pH and SEC (conductivity) of borehole water during drilling will indicate basic water quality, showing immediately if the water is too saline or acidic/alkaline to be drinkable. A more detailed water quality analysis, which will show the levels of potentially harmful elements such as fluoride and arsenic, must be done at a laboratory. Techniques for collecting water samples for laboratory analysis are described in Chapter 7.

5.4.3 Techniques for collecting and analysing chip and core samples

Rock chip samples

A sample of fresh rock chips can be taken from the borehole at regular intervals throughout drilling. The sampling intervals should be such that narrow water-bearing zones are not missed, but not so frequent that too many samples are taken. It is usually good practice to take samples more often where the geology is very changeable – such as in the shallow weathered zone. For a shallow borehole, samples can be taken every 0.5 m, but for a deep borehole this will produce too many samples to be analysed, and a sampling interval of 1.0 m is more practical. The sample must be large enough to allow a good description of the geology to be made – about 300 grams is usually enough.

To take the sample a bucket or spade is placed next to the top of the borehole so that some of the chippings will be captured. It is essential to have a good working relationship with the driller. Where possible the borehole should be



Figure 5.6 Rock chip samples stored in clearly marked plastic bags.

flushed clean before each sample interval to ensure that samples are representative of the labelled depth.

The samples can be stored in clear plastic bags, labelled with the date, the borehole name and/or number and the depth interval (e.g. 21/7/01, Borehole 5, 10.5-11.0 m) (Figure 5.6). If this is not possible, they should at least be stored separately and in order of collection on a cleared area close to the drilling rig (Figure 5.7).

Analysis of rock chip samples

The basic tools required to analyse rock chip samples in the field are a magnifying glass or hand lens, a penknife, a field note book, pencils, and a core box or sectioned narrow plastic pipes, which should be marked with accurate measurement intervals. It is also useful to take colour photographs of the geological samples as a permanent record. Hydrochloric acid can be useful to indicate calcareous rocks, including calcite veins.

For each sample in turn, hard rock chips should be washed so that they can be properly examined. Soft rock fragments from weathered horizons should not be washed as they may disintegrate. The samples are then described geologically, creating a log of the changes in colour, lithology, weathering or fracturing, which will show the depths of permeable, potentially water-bearing horizons. The following parameters should be noted.

- Sample colour - colour helps indicate weathered zones: red colours often indicate oxidation and therefore

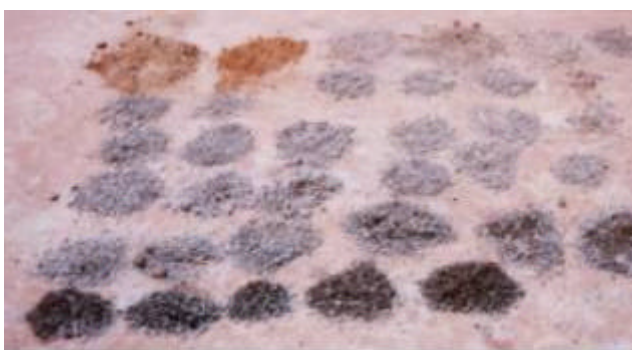

Figure 5.7 Rock chip samples stored separately, in order of collection.

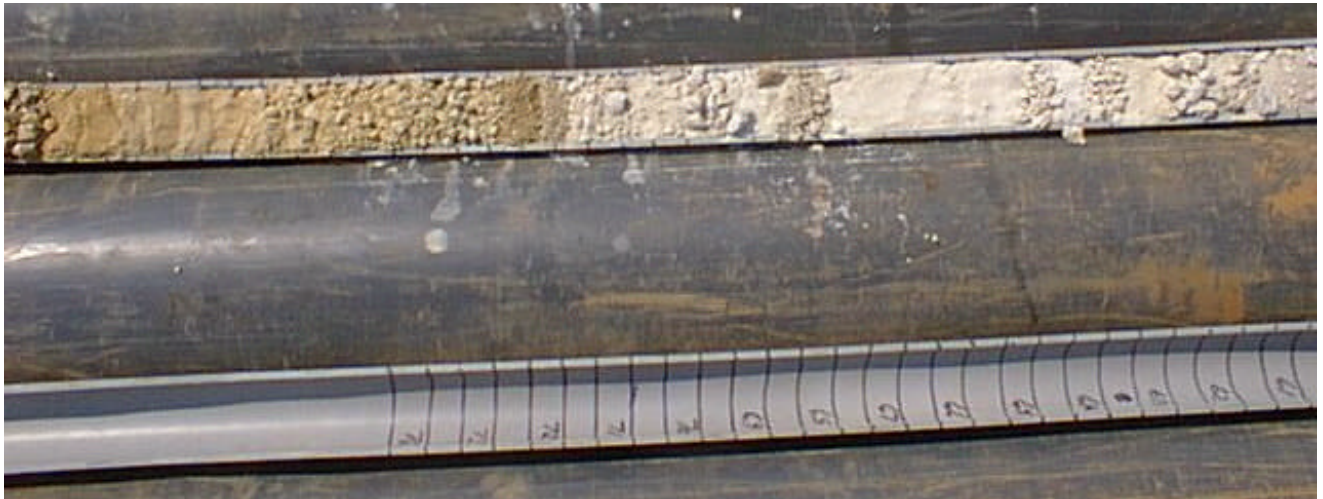

Figure 5.9 Example of rock chip samples displayed in a sectioned pipe.

weathering. Colour can be described using standard colour charts such as those produced by Munsell®.

- Grain size – the size of grains or particles in the rock can be examined using a magnifying glass or hand lens and described using standard charts (see Appendix).
- Relative hardness – weathered rock, in which groundwater is often found, is usually softer.
- The presence of vein material, such as calcite or quartz – veins can be indicators of fracture zones which may be water-bearing.
- The presence of limestone. If the rocks react to hydrochloric acid then calcium carbonate is present.
- The above information can be used to estimate the lithology – e.g. granite, limestone, sandstone etc.

Representative chip samples can then be placed in sequence within a core box or sectioned pipe to show changes in texture and colour with depth. A standard scale should be used (e.g. 5 cm in the sectioned pipe equates to 0.5 m in the borehole). They can then be photographed to provide a permanent record (Figure 5.8).

Cored rock samples

Although chip samples give some idea of lithology, they are no substitute for a cored section of rock. A core can be

taken relatively simply in soft formation such as mudstones, siltstones and sandstones. A specialised core barrel is required, but this can be used with most rigs that can operate down-the-hole hammer. The cost of such a core barrel with bits is less than the price of drilling one borehole.

Core samples give a true, undisturbed sample of the rock at a given depth. Lithological logging of these samples gives a much better idea of the geology than rock chip samples. They can also be used for laboratory analysis of aquifer parameters such as primary permeability and porosity.

A technique that can be used successfully on some rural water supply projects is to take a core from the bottom of each production borehole. This gives invaluable information for only an extra hours work. Even if a hydrogeologist is not on site, the core can be labelled and stored for someone to log later.

Analysis of core samples

Cores should be washed so that they can be properly examined, and then described geologically in the same way as for rock chip samples (Figure 5.9). More information can be gathered on how the rocks are bedded (if



Figure 5.8 A cored sample showing an open fracture in limestone, associated with calcite veining.

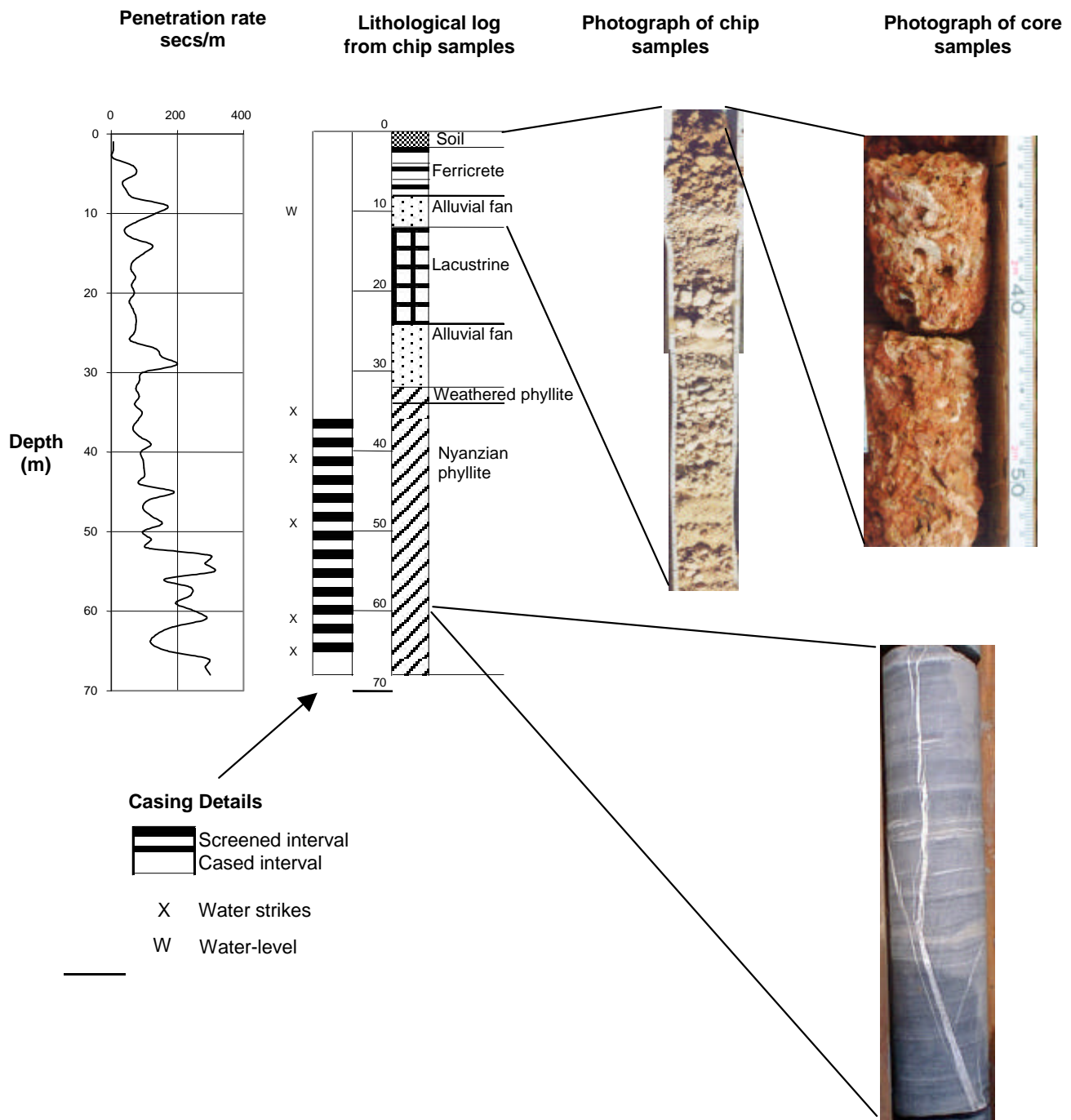

Figure 5.10 An example of the information that can be collected from a routine water supply borehole using some of the simple techniques described in this chapter.

sedimentary). Also a cored sample can give information on fracturing in the rock.

Cores should be photographed, after which samples at known depths can be taken for porosity and/or permeability analysis, macro and micro palaeontological investigation, or petrographic and clay analysis.

Cores can be useful aids for discussing geology with communities. However some sensitivity must be shown when taking samples away from the site, particularly if there is pyrite or chalcopyrite (fool's gold) present!

5.4.4 Putting it all together

Figure 5.10 shows what can be done with the information collected during the routine drilling of a borehole. Photographs are an excellent means of recording information from a borehole, but cannot be a substitute for a lithological description of each sample. Although Figure 5.10 has been drawn up on a computer this is not necessary. A good paper record is better than a poor computer one.

The most important output from the data collection is a lithological log. This shows variations in lithology and also other things of interest such as water strikes or fractures and

Flow logs measure the flow of water within the borehole. For high flows an impeller flow meter can be used but for low flow velocities a heat-pulse flow meter may be required. A flow log will record the direction and rate of flow in a borehole.

Terrain **resistivity** can be measured in a borehole. This is achieved by using a probe with an array of electrodes which pass currents through the rock and measure the resulting potential difference. Changes in resistivity can be given by lithological variation: e.g. clay has a much lower resistance than sands and basement crystalline rocks tend to have a very high resistivity. Resistivity logs must be carried out in an uncased borehole.

Spontaneous potential (SP) is another form of electrical logging. The natural electrical potential between the formation and the borehole fluids is measured. SP can be used for determining bed thickness and can also help identify permeable rocks.

Natural gamma logging measures the natural radiation in rocks as determined by ^{40}K , and the ^{238}U and ^{232}Th decay series. A natural gamma log can identify clays and shales which often contain naturally radioactive material. The technique has the advantage of being unaffected by borehole casing.

Neutron logging is carried out by using a radioactive source. The emitted neutrons are scattered by collisions with hydrogen atoms, and a detector measures the gamma radiation produced by the neutron-hydrogen collision. Thus neutron logging can estimate the moisture content of the rock (which below the water table should correlate to the porosity). However, since the method involves using a radioactive source, some environmental and safety considerations are imperative.

Gamma-gamma radiation is another method that uses a radioactive source, this time ^{60}Co , a source of gamma radiation. The gamma radiation is absorbed by the surrounding material to an extent determined by the bulk density. Therefore the bulk density of the formation can be measured and consequently an estimate of the formation porosity given.

FURTHER READING

ACKER III, W L. 1974. Basic Procedures for Soil Sampling and Core Drilling. Acker Drill Co Inc, 246 pp

AGRICULTURE AND RESOURCE MANAGEMENT COUNCIL OF AUSTRALIA AND NEW ZEALAND. 1997. Minimum construction requirements for water bores in Australia. Queensland Department of Natural Resources Library, pps 86.

CHAPALLIER, D. 1992. Well logging in hydrogeology. AA Balkema/ Rotterdam/ Brookfield, 175 pp.

CRUSE, K. 1979. A review of water well drilling methods. Quarterly Journal of Engineering Geology, vol 12, pp 79-95.

DHV CONSULTING ENGINEERS. 1978. Shallow Wells. Development Cooperation Information Department, Netherlands.

DRISCOLL, F G. 1986. Groundwater and Wells. 2nd edition, Johnson Screens, St Paul, Minnesota

ENVIRONMENTAL PROTECTION AGENCY. 1975. Manual of Water Well Construction Practices. EPA-570/9-75-001.

HARLAN, R L KOLM, K E AND GUTENTAG, E D. 1989. Water-Well Design and Construction. Developments in Geotechnical Engineering, 60. Elsevier

KARANAM, U M R AND MISRA, B. 1998. Principles of Rock Drilling. Balkema, 265 pp.

ROWLES, R. 1990. Drilling for water: A practical manual. Cranfield Press, 180 pp.

WATT, S B AND WOOD, W E. 1979. Hand Dug Wells and their Construction. Intermediate Technology Publications, 253 pp.

6 Assessing the yield of a borehole

6.1 WHY CARRY OUT A PUMPING TEST IN A BOREHOLE?

Routinely undertaking simple pumping tests on community boreholes could make a major contribution to rural water supply programmes. Pumping tests involve measuring the response of water-levels in an aquifer to controlled pumping. From these measurements several pieces of information can be deduced, such as the rough sustainable yield of the borehole and the drawdown within the borehole in response to pumping. Two emerging important issues facing the water sector in sub-Saharan Africa (SSA) could be addressed by routinely undertaking pumping tests.

- *The growing emphasis placed on the sustainability of boreholes and wells.* Many boreholes constructed during rural water-supply programmes fail within a few years. Several factors contribute to borehole sustainability: hydrogeology, engineering, community ownership and cost recovery. Pumping tests can indicate if hydrogeological conditions could compromise sustainability. If simple pumping tests can be carried out prior to installation of casing and screen, projects could save considerable money by choosing not to equip poor boreholes.
- *Decentralisation and privatisation of the drilling of rural water supply boreholes.* The drilling of rural water supply boreholes is now often done by private

contractors and managed by decentralised bodies. Information from pumping tests can be used as an independent check on the work of contractors who are under pressure to maximise profits

There are many different types of pumping test that can be carried out. These range considerably in the sophistication of equipment and complexity of analysis. There are several books available describing these. In this section we describe four simple tests that we have found most useful in assessing groundwater resources. The 'bailer test' is a short test designed by BGS during field work in Nigeria, the air lift test gives a very rough indication of borehole yield. The other two tests are standard tests used throughout the world.

To give a true idea of sustainability, pumping tests should ideally be undertaken at the peak of the dry season, when water levels are at their deepest. In practice, however, tests are usually done while the contractor is on site, after the borehole has been completed. It is important that the time of year that the test is carried out is taken into consideration when looking at the results.

6.2 MEASURING YIELD DURING AN AIRLIFT

A simple way of estimating the yield of a borehole is to measure the discharge of water during air lifting. This is a very approximate method and gives no information about the drawdown in the borehole, and the sustainability of such a yield. Sadly this is often the only method used to



Figure 6.1 Measuring yield during airlift.

assess whether a borehole will be able to sustain the required yield. To measure yield during airlifting, the water blown from the hole must be channelled away from the top of the borehole and through a pipe (see Figure 6.1). A hole is dug in the ground to allow a bucket to stand upright beneath the pipe. The time for the bucket to fill is measured with a stop watch and the flow rate calculated. As the flow rate is often 'lumpy' during airlifting, it should be repeated several times. Table 6.1 describes the advantages and disadvantages of assessing yield during airlift.

Table 6.1 Advantages and disadvantages of measuring yield during airlift.

Advantages	Disadvantages
'Free' information since doesn't require extra time or testing	Highly inaccurate
No lengthy interpretation required	Doesn't measure water levels in the borehole
Can be carried out by drillers	

6.3 THE BAILER TEST

The bailer test is a short simple test, based on sound theoretical principles, to assess whether a borehole can sustain a hand pump serving 250 people. The test comprises removing water from a borehole for 10 minutes using a bailer, and then monitoring the recovery of the water-levels for about 30 minutes. The equipment is cheap and low technology. The most sophisticated equipment is the water-level dipper – indispensable for any groundwater study. The test can be conducted successfully after minimal training and completed within an hour on most boreholes. Analysis of the data can be undertaken at three levels of complexity, varying from a quick 'rule of thumb' to a more reliable estimate of the transmissivity of the aquifer using a computer programme. Such a short test can only give an indication of sustainability – but it is considerably better than not carrying out a test at all or relying only on the yield measured during an airlift.

The bailer test can be used to assess success before

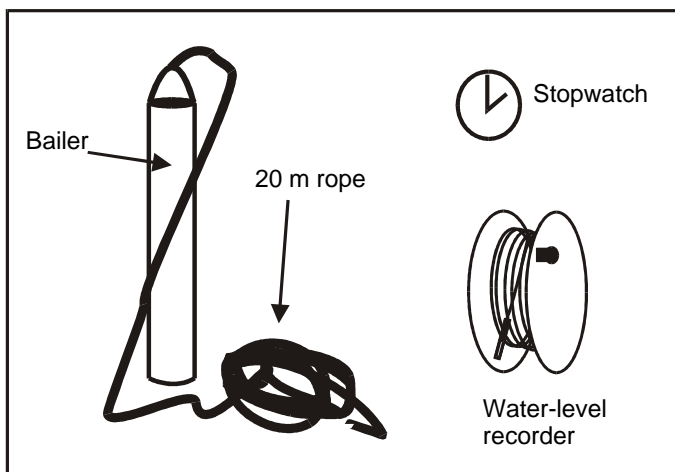

Figure 6.3 Equipment required for a bailer test.



Figure 6.2 Community members helping with a bailer test in Edumoga, Nigeria,

putting screen and casing in the borehole. However, the borehole must have been cleaned out and rested overnight before carrying out the test.

6.3.1 Carrying out a test

The equipment required for carrying out the bailer test is shown in Figure 6.2. Each of the pieces of equipment is described below.

- The *bailer* comprises a long cylindrical bucket that can easily fit down a borehole; it should contain 4 to 5 litres. It can easily be made from 3-inch steel pipe, which would allow about 4.4 litres from a one-metre length. Two bailers should be made to allow pumping to be carried out as fast as possible. A 20-m rope is attached to the top of the bucket.
- A watch (preferably a *stopwatch*) is required to measure the time of pumping and recovery, as is a standard form to record data during the test.
- The most sophisticated equipment required is the *water-level recorder*. This is common to all pumping test methods and is the only realistic method of measuring rapid changes in water-level. The device consists of a two-wire coaxial cable that has electrode separated by an airgap at the lower end. The circuit is completed when both electrodes enter the water and is indicated by a light or buzzer. The cable is graduated, so depth to water-level can be read directly from the cable. Realistically readings can be taken every 15 –

30 seconds, although experienced personnel can take readings more often.

The field procedure for carrying out a bailer test to indicate if a borehole can be equipped with a handpump is straightforward and can readily be undertaken with community help (see Figure 6.3). The procedure is outlined below.

1. The rest water-table is measured in the borehole and the datum from where all readings are to be taken chosen and recorded (e.g. the top of the casing). The water-levels must be at rest prior to the test, therefore the test should not be conducted the same day as drilling or development of the borehole.
2. Bailer A is lowered down the borehole; as the full bail is removed the stopwatch is started. A second bail is removed using Bailer B as the water in Bailer A is emptied. This procedure continues for ten minutes, during which time 20 – 50 bails should have been abstracted, depending on the depth to water-levels. A good guideline figure to aim for is 40 bails in 10 minutes. (Although an even pumping rate is not essential, the test will be more accurate if the rate of removal of the bails is fairly constant throughout the test. Since removing the bails becomes more onerous as the drawdown increases, bail removal should be paced during the first half of the test).
3. After ten minutes bailing, the stopwatch is reset and water-levels measured every 30 seconds for a further 30 minutes. A data form for recording and analysing data is given in the Appendix.

6.3.2 Interpreting the test

Analysis of the data can be undertaken at various levels of complexity, varying from a quick ‘rule of thumb’ to a more reliable estimate of the transmissivity of the aquifer using a

Box 6.1 Criteria for success used in the bailer test

The following criteria were used to define a successful borehole. They are based on a borehole being able to support an India Mk III pump (or equivalent).

- Support 250 people with 25 litres each per day.
- Pumping takes place over a 12 hour period.
- The dry season lasts for 6 months.
- Drawdown within the borehole does not exceed 15 m below rest water level.

computer programme. In this manual we describe only the simplest analysis. However, as long as the data are kept, more sophisticated analysis could be performed at a later stage.

The yes/no/maybe analysis is based on a borehole being able to provide 25 litres per day for 250 people throughout a 6 month dry season. The exact criteria are given in Box 6.1. To interpret the test the following procedure must be followed. A worksheet is also given in the Appendix.

1. Calculate the pumping rate for the test in litres per minute by dividing the volume of water abstracted (in litres) by the length of the test in minutes (usually 10).
2. Calculate the maximum drawdown for the test by subtracting the rest water level from the first water level measurement after bailing stopped (dmax).
3. Read from the data the recovery time for the water-levels to recovery halfway to the rest-water-level (t50).
4. Read from the data the time for the water-levels to recovery three-quarters of the way to the rest-water-level (t75).
5. Use the pumping rate and the drilled diameter of the borehole to find the guideline values in table 6.2.

Table 6.2 Table for assessing the success of a borehole from a bailer test. If the maximum drawdown and time for half and three quarters recovery are all less than quoted here (for the correct borehole diameter and pumping rate) then the borehole is likely to be successful.

Diameter of the borehole ↓	Pumping rate in litres per minute → (Number of standard bails)*	7	10.5	14	17.5	21
		(16)	(24)	(32)	(40)	(48)
4 inch	Max drawdown (m)	3.5	5.3	7.1	8.8	10.6
	time for half recovery (mins)	6	6	6	6	6
	time for three-quarters recovery (mins)	14	14	14	14	14
5 inch	Max drawdown (m)	2.9	4.3	5.7	7.1	8.5
	time for half recovery (mins)	9	9	9	9	9
	time for three-quarters recovery (mins)	21	21	21	21	21
6 inch	Max drawdown (m)	2.3	3.4	4.6	5.7	6.9
	time for half recovery (mins)	12	12	12	12	12
	time for three-quarters recovery (mins)	28	28	28	28	28
8 inch	Max drawdown (m)	1.5	2.3	3.1	3.8	4.6
	time for half recovery (mins)	19	19	19	19	19
	time for three-quarters recovery (mins)	46	47	47	47	47

*Standard bailer is 4.4 litres (1 m long 3 inch pipe)

If the measured values of d_{max} , t_{50} and t_{75} are all less than the values in the table then the borehole is likely to be successful. If the measured values are greater than the guideline values then the borehole is unlikely to sustain 250 people. If some of the values are greater and some smaller, or the values are close to the guideline values then test the borehole using a constant rate test (next section).

6.4 CONSTANT RATE TESTS

6.4.1 What is a constant rate test?

A constant rate test involves pumping a borehole at a constant rate (hence the name) for a certain period (usually greater than several hours) and measuring the change in groundwater levels. Such tests give more information than a short simple test such as the bailer test. The longer the borehole is pumped, the greater the information gathered on the groundwater resources and hence the more confidence that can be put in predictions from the test. The best quality data from constant rate tests are collected by having a purpose drilled observation borehole 10 – 25 m away from the abstraction borehole. However, this is a rare luxury in rural water supply projects, so we will discuss constant rate tests where the water levels are observed in the same borehole that is being pumped.

Analysis of constant rate tests give information about rock *transmissivity*. Transmissivity is one of the fundamental measures of how good an aquifer is. It describes how easily groundwater can flow through a rock to a borehole. A constant rate test which gives transmissivity value of greater than $1\text{m}^2/\text{d}$ should indicate a successful borehole (for the criteria set out in Box 6.1). The other fundamental measure of an aquifer is the storage coefficient – a measure of how much groundwater can be stored in a rock. This can be analysed from long pumping tests with observation boreholes (see books at the end of the chapter). For most cases in sub-Saharan Africa storage is sufficient for a hand pump.

Constant rate tests require the same equipment as a bailer test, but a more sophisticated pump replaces the bailer. Different pumps can be used depending on the



Figure 6.4 Carrying out a pumping test using Whale pumps powered from a car battery.

conditions.

LOW YIELDS

If the borehole is thought to have low yield (<1 litre/s) then a small plastic pump such as a Whale® pump can be used (see Figure 6.4). These pumps are cheap and run from a 12 volt car battery, but they give a fairly steady output at about the same yield as a hand-pump (0.15 l/s). Since the pumps are small, two can be operated in one borehole to give a higher yield. However these pumps should not be run for more than about 5 hours at a time and are not particularly robust.

Alternatively, higher yielding pumps can be used with the discharge reduced. This can be achieved by either putting a valve on the discharge of the pump, or diverting some of the abstracted water back down the borehole (in this case, however, it will be difficult to measure water levels during pumping in the borehole and only recovery data can be collected).

HIGHER YIELDS

If the yield of the borehole is higher, then electrical submersible pumps can be used, such as Grundfos® pumps. These require generators and can pump from 0.5 litres per second upwards. Such systems are robust, and fairly easy to install, but rely on a good quality generators and the availability of clean fuel. They are also expensive compared to the low yielding Whale® pumps. If groundwater levels are shallow, a centrifugal pump can be used. These will only work at depths shallower than 7 m, and have yields considerable higher than a hand pump.

6.4.2 Carrying out a short constant rate pumping test

1. Wait at least 12 hours from previous drilling, pumping or airlifting.
2. Install the appropriate pump (choose pump from approximate yield during the airlift).
3. Make sure the discharge hose is a few tens of metres from the borehole (can be closer for a Whale® pump where discharge is small)
4. Measure rest-water-level with a water-level dipper and mark measuring point on borehole casing.
5. Start pump and stop watch simultaneously.
6. Measure water-level every 30 seconds for first 10 minutes, every 1 minute until 30 minutes; 5 minutes to 2 hours and 10 minutes beyond.
7. Periodically measure the pump rate using a bucket and stopwatch for Whale® pumps and a oil drum for higher yielding pumps.
8. The test should last at least 5 hours.
9. Switch off the pump (note total time of pumping) then reset stopwatch. Measure recovery in same fashion as drawdown (i.e. 30 seconds for first 10 minutes etc.).
10. Continue to measure recovery until the water-level has recovered to 75% of its original rest-water-level.

As with all fieldwork, keeping a neat and detailed notebook is essential. Since readings are taken every few seconds at the beginning of the test it important to write in the notebook the times for readings before starting or get someone else to help. Figure 6.5 shows an example of a notebook for a drawdown and recovery test.

Date: 16 April 2001
 Village: Omollo 44.322°N 9.212°E
 Borehole Number: NK43

Two Whale pumps
 Rest water level = 4.3 m
 Height of casing = 0.32 m

Test started at 8:15 am
 Water levels measured
 from top casing
 Steven Obilla

Time	Water level
30 secs	4.43
1 min	
1 min 30s	4.52
2 mins	4.62
2 mins 30s	4.71
3mins	4.80
3 mins 30s	4.895
4 mins	4.98
4 mins 30s	5.07
5 mins	5.155
6 mins	5.31
7 mins	5.445
8 mins	5.58

1 min 38 secs
 to fill 15 litre
 bucket

1 min 37 secs
 to fill 15 litre
 bucket

Figure 6.5 Example of a notebook recording water-levels during a constant rate pumping test.

RECOVERY ANALYSIS

The best quality data to analyse from a pumping test is the recovery data (the water-levels recorded after the pump has been switched off). This is because the recovery smooths out any small changes in pumping rate and after the first few seconds there are no errors due to well losses. A worksheet is given in the Appendix for analysing This recovery data. A summary is given here.

- For the recovery part of the test, calculate the residual drawdown (s') by subtracting the rest-water-level (measured before pumping started) from the measured water-levels.
- The time elapsed since the start of the recovery is known as t' . For each recovery water-level calculate the time elapsed since the very start of the test (t). For example - if the pump was pumping for 300 minutes before it was switched off, and recovery water levels were measured at 0.5, 1 and 1.5 minutes, t would be 300.5, 301 and 301.5 minutes respectively, and t' , 0.5, 1 and 1.5.
- Divide t by t' (i.e. t/t')
- Plot the residual drawdown s' against t/t' on semi-log paper - t/t' on the log scale, with s' on the arithmetic scale. Photocopy the semi log paper in the Appendix or use tracing paper. Residual drawdown should be in metres. The data should plot roughly as a straight line. Draw a best fit line through the data - using mostly data from low t/t' values (Figure 6.5).
- Measure $\Delta s'$ from the best fit line (see Figure 6.5). $\Delta s'$ is the difference in water levels over one log cycle of time (a log cycle is either 1-10; 10-100 or 100-1000).

- Calculate the average pumping rate (Q) for the pumping test in m^3/day . To change from litres/second, multiply by the number of seconds in a day ($60 \times 60 \times 24$) and divided by the number of litres in a cubic metre (1000).
- Substitute Q , and $\Delta s'$ into the formula below to find the transmissivity, T (measured in m^2/day).

$$Transmissivity = \frac{0.183 Q}{\Delta s'}$$

As discussed above, if the transmissivity is greater than $1 m^2/d$ then the borehole is likely to sustain a handpump.

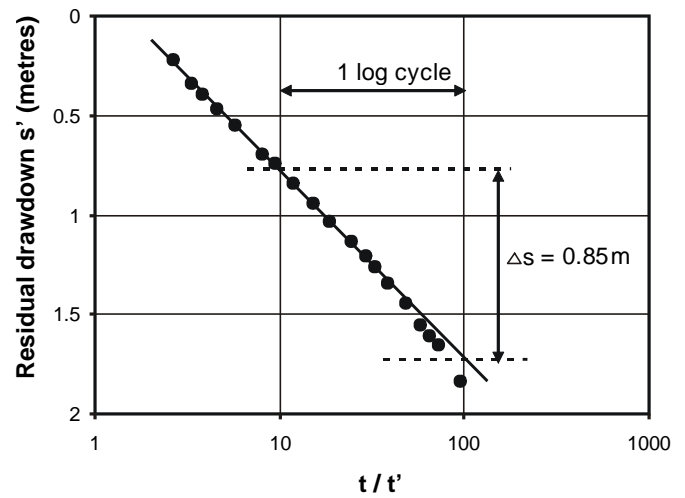

Figure 6.6 An example of measuring $\Delta s'$ from recovery data.

DRAWDOWN ANALYSIS

Useful information can also be gathered from analysis of data measured during pumping. Although not as reliable as recovery for estimating transmissivity, additional information can sometimes be given about fractures in the rock. A worksheet is given in the Appendix for analysing the data.

- Plot the water-levels from the start of the test to when the pump is switched off against time on semi-log paper - time on the log scale, with water-levels on the arithmetic scale (see Figure 6.7). Photocopy the semi log paper in the Appendix or use tracing paper. The time is the number of minutes since pumping started; water-levels should be plotted in metres below casing. The data should plot roughly as a straight line. Draw a best fit line through the data - using mostly the middle or later data (Figure 6.7).
- Measure Δs from the best fit line. Δs is the difference in water-levels (in metres) over one log cycle of time (a log cycle is either 1-10; 10-100 or 100-1000).
- Calculate the average pumping rate (Q) for the pumping test in m^3/d . To change from litres/second, multiply by the number of seconds in a day ($60 \times 60 \times 24$) and divide by the number of litres in a cubic metre (1000).

4. Substitute Q , and s into the formula below to find the transmissivity T (measured in m^2/d).

FURTHER READING

KRUSEMAN, G P & DERIDDER, N A. 1990. Analysis and evaluation of pumping test data. International ILRI Publication 47, Institute for Land Reclamation and Improvement, The Netherlands.

BUTLER, J J. 1997. The design, performance and analysis of slug tests. Lewis Publishers, New York.

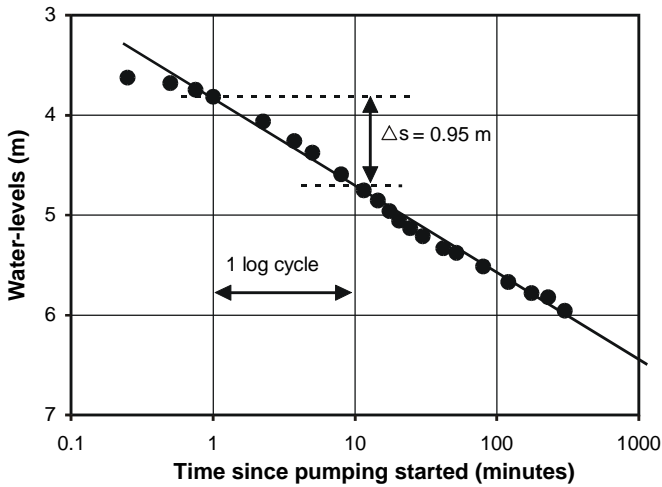

Figure 6.7 Measuring s from a drawdown curve.

$$Transmissivity = \frac{0.183 Q}{\Delta s'}$$

As discussed above, if the transmissivity is greater than $1 m^2/d$ then the borehole is likely to sustain a handpump.

If the gradient of the line changes and the rate of decrease of the water-levels increases (see Figure 6.8), a fracture may have been emptied. If possible draw a new line through these points and calculate the transmissivity. If it is less than $1 m^2/d$, the borehole may encounter problems, and not continually sustain a handpump. However make sure that the pumping rate had not changed at this point. If the pumping rate had increased suddenly the rate of drawdown would increase. Therefore make sure that the pumping rate is checked often enough to be able to accurately determine the reason for any changes in slope.

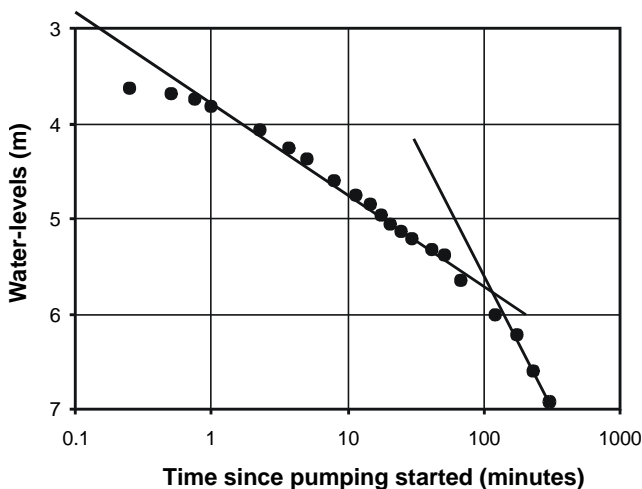

Figure 6.8 Any deviations from a straight line in a Jacob plot can give useful information about an aquifer.

7 Simple methods for assessing groundwater quality

The quality of water from a borehole is almost as important as the yield of the borehole. Although in most cases water from aquifers is of excellent quality and needs no treatment before it is used for drinking, there are some natural elements and pollutants which can make groundwater taste or smell unacceptable, or even make it harmful to health. Assessing the chemical quality of water in a borehole is therefore always useful, and in some environments, vital.

This chapter provides a brief introduction to groundwater quality. References to a series of texts and papers are given at the end of the section. Guidelines for the concentrations of constituents are given by the World Health Organisation WHO (see Table 7.1 and 7.2)

Microbiological assessments are not discussed. To properly assess the presence of pathogens in a borehole it should be done several years after the borehole is constructed.

7.1 GROUNDWATER QUALITY

The natural quality of groundwater is largely controlled by the geology of the aquifer and the length of time water is stored in the ground (the residence time), although it can be affected by climate and the nature of recharge water. Groundwater contamination of rural aquifers is most often a result of poor sanitation, where faecal matter (from humans or cattle) enters the aquifer. This can happen around the wellhead if cattle are allowed to drink at the well (which is why it is important that boreholes are properly sealed and that effective sanitary surrounds are completed at all boreholes). It can also happen when pit latrines are built in a shallow aquifer from which water is abstracted, such as ferricrete, so that faecal waste can flow from the latrines into the aquifer.

Table 7.1 World Health Organisation guidelines for drinking water quality: inorganic chemicals of health significance in drinking water.

Substance	Guideline value (mg/litre)	Remarks
Antimony	0.005 (P)	
Arsenic	0.01 (P)	For excess skin cancer risk of 6×10^{-4}
Barium	0.7	
Beryllium		NAD
Boron	0.5 (P)	
Cadmium	0.003	
Chromium	0.05 (P)	
Copper	2 (P)	Based on acute gastrointestinal effects
Cyanide	0.07	
Fluoride	1.5	Climatic conditions, volume of water consumed, and intake from other sources should be considered when setting national standards
Lead	0.01	It is recognised that not all water will meet the guideline value immediately; meanwhile, all other recommended measures to reduce the total exposure to lead should be implemented
Manganese	0.5 (P)	ATO
Mercury (total)	0.001	
Molybdenum	0.07	
Nickel	0.02 (P)	
Nitrate	50 (acute)	
Nitrite	3 (acute) 0.2 (chronic)	
Selenium	0.01	
Uranium	0.002 (P)	

P – Provisional guideline value

NAD – No adequate data to permit recommendation of a health-based guideline value

ATO – Concentrations of the substance at or below the health-based guideline value may affect the appearance, taste, or colour of the water.

Table 7.2 World Health Organisation guidelines for drinking water quality: inorganic substances and parameters in drinking water that may give rise to complaints from customers.

Physical Parameters and inorganic constituents	Levels likely to give rise to consumer complaints	Reason for consumer complaints
Colour	15 TCU	Appearance
Taste and odour	-	Should be acceptable
Temperature	-	Should be acceptable
Turbidity	5 NTU	Appearance; for effective terminal disinfection, median turbidity = 1 NTU, single sample = 5 NTU
Aluminium	0.2 mg/l	Depositions, discolouration
Ammonia	1.5 mg/l	Odour and taste
Chloride	250 mg/l	Taste and corrosion
Copper	1 mg/l	Staining of laundry and sanitary ware (health based provisional guideline value 2 mg/l)
Hardness		High hardness: scale deposition, scum formation Low hardness: possible corrosion
Hydrogen sulphide	0.05 mg/l	Odour and taste
Iron	0.3 mg/l	Staining of laundry and sanitary ware
Manganese	0.1 mg/l	Staining of laundry and sanitary ware (health based guideline value 0.5 mg/l)
Dissolved oxygen		Indirect effects
PH		Low pH: corrosion High pH: taste, soapy feel
Sodium	200 mg/l	Taste
Total dissolved solids	1000 mg/l	Taste
Zinc	3 mg/l	Appearance, taste

TCU – True colour unit
NTU – nephelometric turbidity unit

The most common natural elements which can cause health problems are fluoride and arsenic. Most groundwaters have low levels of both elements, but in certain areas and aquifers the concentrations of one or the other can be high enough to cause health problems. Some aquifer types are more likely to have high fluoride or arsenic concentrations than others (see Chapter 2). If groundwater is being extracted from such an aquifer type, samples should be taken from several boreholes throughout an area to assess whether these chemicals are present in the area. If they are, then each borehole should be tested before commissioning.

High fluoride concentrations tend to occur where fluorine-bearing minerals (particularly fluorite, apatite and micas) are abundant in aquifer rocks. Fluoride levels over 1.5 mg/l (the WHO recommended limit) can lead to dental fluorosis, particularly in young children (visible as semi-regular brown stains on teeth). Fluoride levels over 4 mg/l can lead to serious skeletal fluorosis. However, it is important to note that additional factors such as poor nutrition (particularly calcium and vitamin C deficiencies) are important in determining the course of fluorosis. Crystalline basement rocks, especially granites, often contain abundant fluoride-bearing minerals. The main areas of Africa where high fluoride groundwaters are a particular problem are parts of West Africa (Ghana, Ivory Coast and Senegal), South Africa, and the East African Rift area (parts of Kenya, Uganda, Tanzania, Ethiopia and Malawi).

Because fluoride levels in groundwater tend to build up over long time periods, shallow groundwaters from hand-dug wells usually have lower concentrations, as they represent young, recently recharged water. Deeper, older groundwaters in at-risk aquifers are most likely to contain high fluoride concentrations. High fluoride concentrations are also a feature of arid climatic conditions, where groundwater flow is slow and there has been more dissolution of fluoride-bearing minerals from the aquifer rocks.

High arsenic concentrations in groundwater can occur naturally or can be exacerbated by local mining activities. Arsenic is a toxin and a carcinogen (cancer-causing), and long-term arsenic intake has been linked with skin disorders and more serious health problems such as skin cancers, diabetes and cardiovascular, neurological and respiratory diseases. Most groundwaters have concentrations of less than 10 µg/l, but concentrations up to 3,000 µg/l or more are seen in some conditions. The national standard for arsenic in most countries is 50 µg/l, although the WHO recommended limit is only 10 µg/l. Groundwaters which are naturally high in arsenic tend to be found in geologically young aquifers (i.e. sediments deposited in the last few thousand years) or where groundwater flow is very slow. Up till today no aquifers with naturally high arsenic levels are known of in Africa, although arsenic contamination of groundwater resulting from mining has been observed in Ghana, Zimbabwe and South Africa.

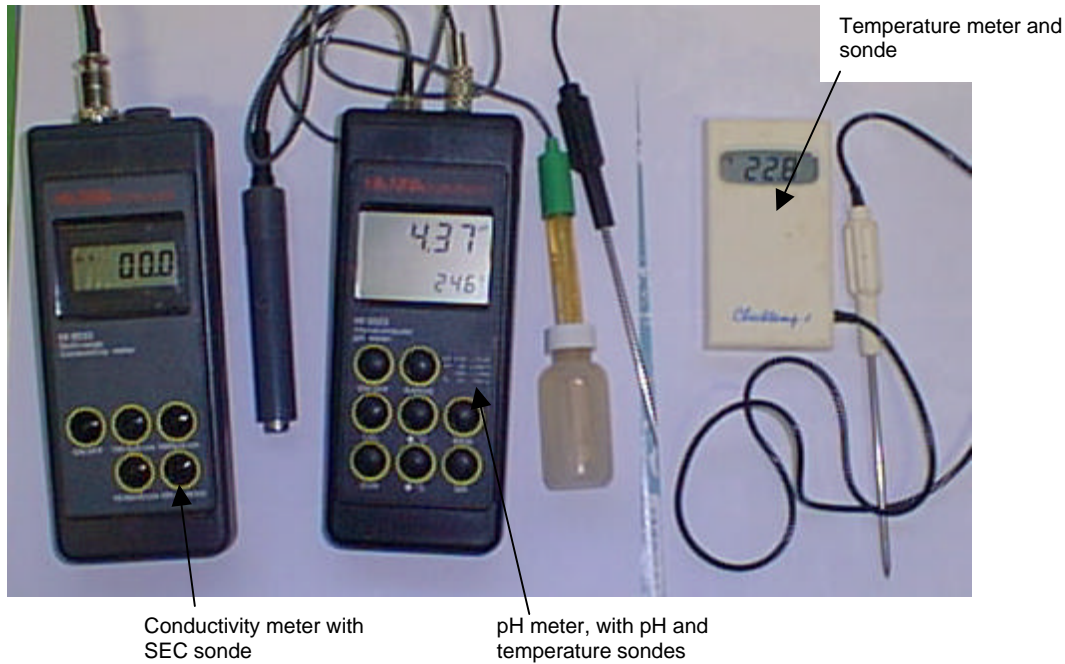

Figure 7.1 Simple field equipment for estimating water quality.

Elevated iron and manganese can also cause problems for rural water supply. Although there are no real health problems associated with them, they can make the groundwater unpleasant to drink or use. They can give the water a bitter taste and can also anything washed in the water.

7.2 SIMPLE MEASURES OF WATER QUALITY

Detailed chemical analysis can only be undertaken in a laboratory with water samples taken in a controlled manner. However, some chemical parameters, such as salt content, pH and the presence of E-coli, can be easily approximated in the field. Good meters are available for easily measuring these (see Figure 7.1). However meters must be calibrated frequently to keep them giving accurate readings. This can be particularly important in field conditions where meters are subjected to large changes in temperature, and can get dirty etc... Easy to use, reliable field kits are also available for some specific parameters, such as fluoride, and are being developed for arsenic (see below).

Before taking a measurement, the borehole should be pumped for some time to make the water being sampled is from the aquifer and not stale water in the borehole. A rough rule of thumb often used is to pump out the equivalent of three borehole volumes.

Each borehole should be tested for specific electrical conductance (SEC). SEC can give a rough estimate of the salt content of the water. SEC is generally measured in mS/cm at the reference temperature of 25°C. Most modern meters will automatically give this reading, compensating for the different temperatures. To roughly assess salt content the SEC is multiplied by 0.7 to give the total dissolved solids (TDS) in mg/l. The WHO standard is 1000 mg/l. However in some circumstances and cultures higher salt contents are acceptable. High TDS may quickly destroy pipe work (see Figure 7.2).

The pH can give an indication of the condition of the groundwater. If the pH is acidic, then pipework may quickly corrode. Low pH may also allow harmful metals to dissolve, such as aluminium, cadmium etc and encourage high iron concentrations.

The presence of iron or manganese can be detected with a simple settling test. Water from the borehole can be kept in a bucket for an hour. If iron or manganese is present they will have precipitated by this time. Iron is detected by the presence of small orange/brown particles, and manganese by small black/purple particles.

Simple fluoride analysis can be carried out using low cost, pocket colorimeters, supplied as kits with reagent solutions for field use. Most current field test kits for arsenic are usually good at detecting high concentrations (over 100 mg/l), but are not reliable enough at concentrations of less than 50 mg/l. One new field kit currently being developed and tested, the 'Arsenator Light', has improved sensitivity and precision and is easy to use and calibrate.

7.3 DETAILED ANALYSIS

There are many parameters that cannot be analysed in the field. With the growing knowledge about the effects of water chemistry on health, it is becoming apparent that water chemistry cannot be ignored. As part of any rural water supply project, therefore, a detailed assessment of water quality should be considered. This is outside the scope of this manual.

Water samples should be taken and analysed for a full suit of major ions, plus important minor ions. Good quality laboratories are required to carry out the analysis, and rigorous sampling.

FURTHER READING

APPELO, C A J, AND POSTMA, D. 1994. *Geochemistry, groundwater and pollution*. A A Balkema, Rotterdam.

APPLETON, J D, FUGE, R, AND MCCALL, G J H (EDS.) 1996. *Environmental geochemistry and health*. Geological Society London Special Publications, **113**.



Figure 7.2 Highly corroded rising main from a borehole with TDS greater than 3000 mg/l. New rising main corroded within one year.

8 Using the information to build a regional picture

The techniques described in this manual are useful for siting and commissioning wells and boreholes. Used in earnest they should help to increase significantly the success rate of sustainable water supplies. The techniques also produce information that can help to build a picture of how groundwater exists in an area, and therefore inform future decisions about water projects.

8.1 WHY IS UNDERSTANDING THE REGIONAL HYDROGEOLOGY USEFUL?

Understanding how groundwater exists in an area can have many benefits. A few are outlined below.

- *The use of appropriate methods and technology.* By understanding how groundwater exists in an area the most effective technology can be used. For example if most of the groundwater exists in fractures at depths between 50 and 80 m then deep boreholes are the best option. If groundwater is known to be hard to find in part of the area more resources should be spent on widespread surveys to find the best location for a well or borehole.
- *Significantly reduced costs.* Targeting appropriate technology and using the appropriate siting and construction methods will increase the success rate of water projects. Even a small increase in success will lead to dramatic savings.
- *Helps credible relationships with communities.* Understanding the hydrogeology of an area, and therefore the likely success of any intervention, is a great benefit in discussions with communities. Realistic scenarios can be discussed, and if the hydrogeology is sufficiently well understood simple models can be used to help discussions.

8.2 KEEPING HOLD OF INFORMATION

To help build up a general picture of the existence of groundwater in an area, information from different sources needs to be pieced together. By far the most important source is from borehole geological logs and pumping tests.

Hydrogeological information and data are precious. The real cost of drilling and completing a borehole throughout much of Africa is somewhere between £5000 and £10 000. Gathering information on geology and borehole yields costs only a small fraction of this amount (typically less than 5%). However, to go out and deliberately drill an exploration borehole for the same information could cost the full £5000 - £10 000. In some situations where the geology is highly complex and there is little information such an investment is justified (see MacDonald and Davies 2000). More commonly, however

it is much more cost effective to gather and hold on to information from routine drilling.

To build up an unbiased regional picture it is also vital to hold onto information from unsuccessful boreholes. This information is as useful as that from a successful borehole. It should help build up the picture of areas to be avoided. This is particularly useful when comparing the results from geophysics to that actual geological logs.

Sometimes arguments can arise about data ownership. Contractors who undertake geophysical surveys, geological logging and pumping tests can be reluctant to part with data. This is partly due to time constraints. It can take a day or so in the office to get data from a field notebook into a form that someone else can understand. More seriously however is the belief that knowledge and information is power. The concern may be that another contractor will use the geophysical data to site additional boreholes.

As a basic rule, whoever pays for the work to be carried out should have access to the data. For clarity, this should be written into every contract. Having access to all the data not only helps to build up a database of the hydrogeology, but also acts as a very useful check on what the contractor has done. The information can be audited by project managers and other professional water engineers or hydrogeologists.

As a safeguard against loss, copies of data should be held by various people. This could include the contractor, partners, funders, and communities. The more that information is spread around, the more likely it is not be lost and to be used in the future.

8.3 A SIMPLE DATABASE

Databases can be very simple. An ordered filing cabinet with community files can be as useful as any computer database. To be of use for building up a picture of the hydrogeology the following information is necessary:

- village name;
- co-ordinates;
- geological log including water strike;
- information on successful or unsuccessful;
- borehole yield or transmissivity;
- copies of siting methods.

To help get a regional view of groundwater resources the borehole locations should be plotted on a map. This can be done easily using topographic maps which are available for much of Africa. To help preserve the maps they can be laminated, or if that's not possible then photocopies can be made and the original ones kept good. Different coloured stickers can be used for successful and unsuccessful boreholes and the village name and borehole reference number written beside it. If geological maps are available for the area than the geological boundaries can also be drawn on.

With time this information will form a very useful database. Patterns should begin to emerge on the map which will help future drilling. Geological logs can be classified into different types and hopefully linked into existing geological maps. The water strikes can be linked to the geology – maybe they are usually associated with fractures at a certain depth, or a change in colour of the sandstone. The geophysical surveys can be compared to the geological logs and borehole/well yields. The way that the geophysical surveys are interpreted can then be updated.

type.

It is easy to get distracted by the possibility of making colourful maps or presenting various pieces of information. The main task should always be kept in mind – siting and constructing sustainable and appropriate water supplies for the least cost.

8.4 THE FUTURE?

If all the data is kept, it can easily be transferred onto computer to help build a computer database linked to maps using GIS. However this should not replace a filing system – computers can easily go wrong and information be lost. In fact a good paper filing system is much better than a poor computer system. A computer database must be carefully constructed, so that all the key information is contained. It may form part of a larger database with sociological information about different villages.

The main benefit of a GIS is that it allows different maps to be constructed very quickly to help see regional patterns. For example a map of the salinity of water samples can be quickly made, and maybe it will show patterns associated with different rock types. Borehole yields can be plotted, and again could show important variations across different environments. Where there is sufficient information, borehole logs can even be used to make new geological maps logs. Health data where available can be linked to geology. For example GIS analysis in Nigeria helped to show that most guinea worm cases were associated with a certain low permeability rock



Figure 8.1 Project staff using a groundwater development map produced on a GIS using the techniques described in this manual.

Appendix 1 Fact sheets on techniques and methods

Cable Tool Percussion Drilling

This is the main method used to drill boreholes into unconsolidated sediments. Collection of representative samples is possible during drilling. The operating capacity of a cable tool percussion rig is limited by the weight of tools and temporary steel casing strings that can be handled safely. The main components of the drilling system are illustrated above. A full string of drill tools comprises drill bit, drill stem, drilling jars, swivel socket and cable. A bailer suspended on a sand line, strings of heavy duty temporary casing of decreasing diameter (e.g. 10", 8" and 6"), and high capacity jacks to retrieve temporary casing, are also needed. A rig may be truck or trailer mounted, with additional tools carried on a support vehicle. The rigs are relatively simple to maintain, making them popular in Africa where access to spare parts and servicing facilities is lacking. The maximum diameter of water boreholes drilled using this method is 12 to 14".

In cable tool percussion drilling there are three main operations:

- the breaking of rock by the repeated lifting and dropping of the drilling bit
- the removal of the rock cuttings with a bailer
- driving temporary casing down the borehole as drilling proceeds to prevent borehole collapse

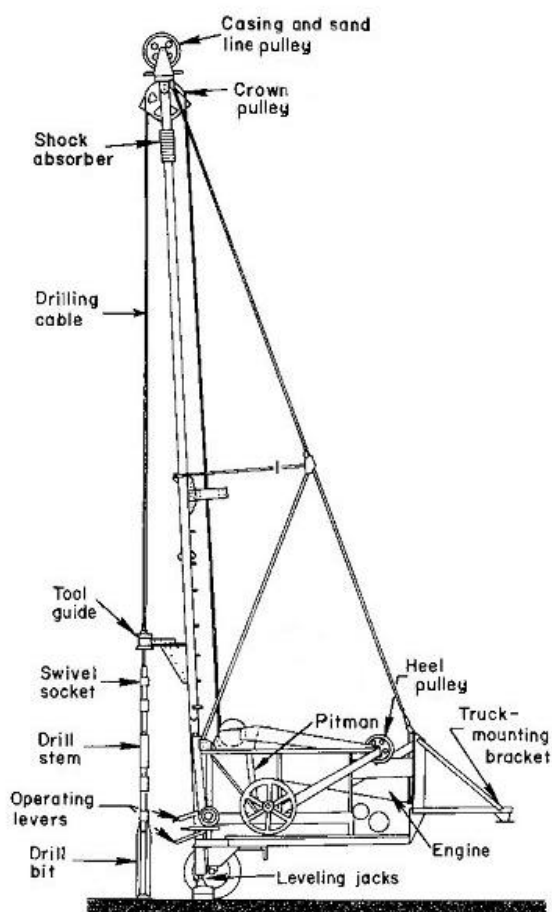

Basic components of a cable tool percussion drilling system (after Harlan *et al.*, 1989.)

The drilling bit needs to be heavy enough to break, crush and mix sediments and rocks. It should be about 2" larger than the maximum casing size. The drill stem provides additional weight and helps to maintain a vertical hole alignment during drilling. Drilling jars are used to free the bit when drilling through soft and sticky sediment. The reciprocating action of the tools mixes the rock fragments with water, derived from the formation or added during drilling, to form a slurry which is then removed from the borehole using a bailer. As the borehole is deepened, the temporary casing is emplaced, starting with the maximum diameter and reducing in diameter if harder strata are encountered. Three or four bits of each diameter used are needed to drill in hard formations. These need to be sharpened and redressed to the correct diameter daily.

Mobilisation to site takes up to 2 days; borehole drilling can be slow, on the order of weeks (compared to days with the mud flush method); and borehole construction can take up to 3 days because of the time taken to remove temporary casing.



Photograph of percussion rig in use.

Direct Rotary Drilling

This method can rapidly drill boreholes into unconsolidated sediments and consolidated sedimentary, igneous and metamorphic rocks. Good representative samples can be collected during drilling. Borehole up to 610mm (24") diameter can be drilled. Drilling rigs using this system are widely available and are typically truck-mounted. For the air-flush method a truck or trailer mounted compressor is used; for the mud-flush method a mud pump is used. The drill string, including a drill bit and drill pipes, is rotated using a top head drive. The drill bit rotates, disaggregating, breaking and crushing the rock formation. Rock cuttings are removed by flushing the borehole with air, mud or water. Tricone roller rock-bits and drag bits are used to drill boreholes within unconsolidated sediments. Hard formations are drilled using tungsten carbide insert rock roller bits.

The mud-flush rotary method is used primarily in unconsolidated sediments. Mud is pumped through the drill pipe and holes in the bit; the mud swirls in the bottom of the hole, picking up material broken by the bit and flows upward in the annular space between the drill pipe and the wall of the borehole to carry the cuttings to the surface. The drill pipe and bit move progressively downward, deepening the hole as the operation proceeds. At the ground surface, the mud flows into a settling pit where the cuttings settle to the bottom. From the settling pit the mud is recycled through the drill pipe using the mud pump. Casing is not put into the hole until drilling operations are completed, as the walls of the hole are supported by the weight of the mud. Mud cake can be difficult to remove, making well development more difficult after construction. A biodegradable mud should be used if possible; the use of bentonite mud should be avoided as it is particularly hard to remove during development.

The air-flush rotary method is used principally in hard clay or rock formations. Air supplied by a compressor is

forced down the drill pipe and through the drill bit, acting to cool it, and then flushes cuttings up the annular space and out of the borehole to be collected and cleared away at the top. An injection pump is used to inject small quantities of water or foam into the drill string during drilling to suppress dust or to improve the up-hole lifting capacity of the return air stream.

Mobilisation and site preparation takes up to 1 day; boreholes up to 100 m deep can be drilled in a few days; and borehole construction takes about 2 days.



Drag bit with reamer for drilling unconsolidated formations



Tricone rock roller bit with tungsten carbide teeth

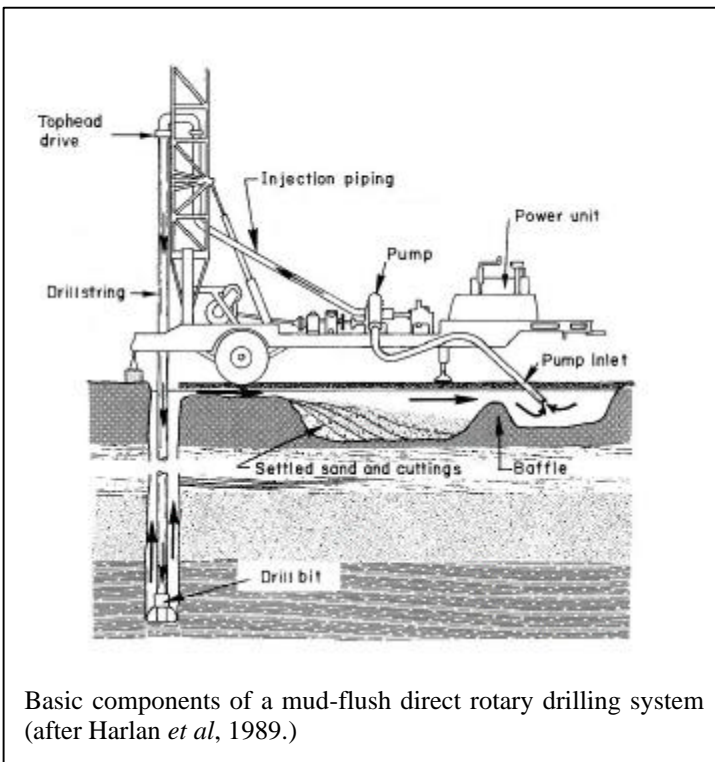

Rotary Down the hole Hammer Air-flush Drilling (DHD) method

This method is used to rapidly drill boreholes in hard rock formations. Good collection of representative samples is possible during drilling. Drilled borehole diameter is limited to a maximum of 410 mm (15 inch). Drilling rigs using this method of drilling are widely available throughout sub-Saharan Africa. The method uses an air-operated drill combining the percussion action of cable tool drilling with the turning action of rotary drilling. The air drill can be used on a standard rotary rig with a suitable air compressor. A typical system includes a truck mounted drilling rig, a truck or trailer mounted compressor and a support truck with additional equipment. The drill string, comprising a drill hammer and bit, collars, stabilizers and drill pipes, is rotated by a top head drive. To start boreholes off in soft near-surface soils and shallow weathered strata, tricone roller rock-bits and drag bits are used; in deeper hard rock formations a down the hole hammer with tungsten carbide insert button bit is used. Cuttings and inflowing water are lifted out of the borehole using air supplied by a compressor of sufficient capacity.

Compressed air is forced down the drill pipe to activate the hammer at the end of the drill string. The bit is rotated slowly at 5-15 rpm. Air passes through the drill bit and flushes cuttings up the annular space to the top of the borehole, where they are collected and cleared at regular intervals. Continuous hole cleaning exposes new rock so that no energy is wasted in re-drilling old cuttings. For optimum up-hole velocity during drilling, the drill rod diameter must match the borehole diameter and air pressure/volume of flow. An injection pump can be used as necessary to inject small quantities of water or foam into the drill string during drilling to suppress dust or to improve the lifting capacity of the return air stream.



Down the hole hammer with button bit attached



Down the hole hammer

Measuring electrical conductivity using the EM34

General

The EM34 estimates the electrical conductivity of the ground. It is a simple method which allows rapid surveying to be done. It measures the same physical property as resistivity. Although the method is straightforward, there are a number of important factors that must be taken into consideration when using it. These are discussed here.

Setting up

1. Choose the appropriate cable for the separation you want to use. For a general survey, 20 m separation is best. A coil separation of 40 m is useful for looking deeper into the ground for dolerite or sandstone at depth. Connect up the coils and transmitter and receiver consoles as described in the manual.
2. Carry out the daily checks – check that both the transmitter and receiver batteries are ok. The receiver batteries should read more than 4.5 volts in the battery + and – position. The nulling of the instrument should also be checked (see overleaf).
3. Every few weeks carry out the full set of checks as described in the equipment manuals.

The operation of the instrument

On both the receiver and transmitter, the separation should be set to the appropriate distance (20 m etc). Start with the sensitivity switch at 100 mmhos/m. If the readings become less than 10 then change to the 10 setting. If they become more than 100 then change to the 1000 setting. A meter on the receiver consul shows the error in the intercoil spacing; the receiver coil can then be moved until the error is negligible (and the needle is in the middle). The terrain conductivity can then be read directly from the receiver consul in mmhos/m.

The coils can be orientated either vertically or horizontally. Different orientation changes the direction of the inducing field and what the instrument is sensitive to. **For vertical coils the reading gives a good estimate of the electrical conductivity** (in mmhos/m). The maximum contribution is from the ground surface, and the response reduces with depth; the average depth of penetration is about 0.5 - 0.7 x the coil spacing. Horizontal coils do not give a good estimate of electrical conductivity beyond about 30 mmhos/m. In fact the highest reading the horizontal coils can give is 65 mmhos/m! However, **when the instrument is used with horizontal coils it is sensitive to vertical conductors**, such as dolerite dykes or vertical fractures - often good targets for groundwater. When passing over a vertical anomaly a *negative* response is given. Sometimes this can actually give readings of less than zero, which at first can be rather confusing!

When the coils are horizontal, the readings are very sensitive to misalignment of the coils. With vertical coils the instrument is not sensitive to misalignment of the coils, but is rather more sensitive differences in intercoil spacings.

Tips for undertaking EM34 survey

1. Make sure that the stickers on the coils are pointing in the same direction.
2. Make comments in the notebook, so that you can easily relate the survey to the ground. Use the SDVHC system (station, distance, vertical coil, horizontal coil, comments). Always be certain that the distance and comments marked in the notebook are from the receiver. It is usually easier if the receiver is always trailing.
3. Metal objects close by, such as cars and zinc roofs will give slightly anomalous readings when the coils are horizontal (but is not as sensitive as the magnetics).
4. If the coils are not exactly horizontal, they will give erroneous readings. If you can't get the coils horizontal, then mark this in your notebook and treat the data with caution.
5. When trying to find dolerite or Agbani Sandstone, repeat surveys with 40 m coil spacing.
6. Interpreting the data depends very much on the geological conditions. See the comments on interpreting data in the BGS report CR/01/168N.

IMPORTANT

Never turn the receiver and transmitter on when they are near each other – this will damage the electronics.

Never try to recharge normal batteries.

Alan MacDonald
British Geological Survey
amm@bgs.ac.uk

conductivity (mmhos/m)

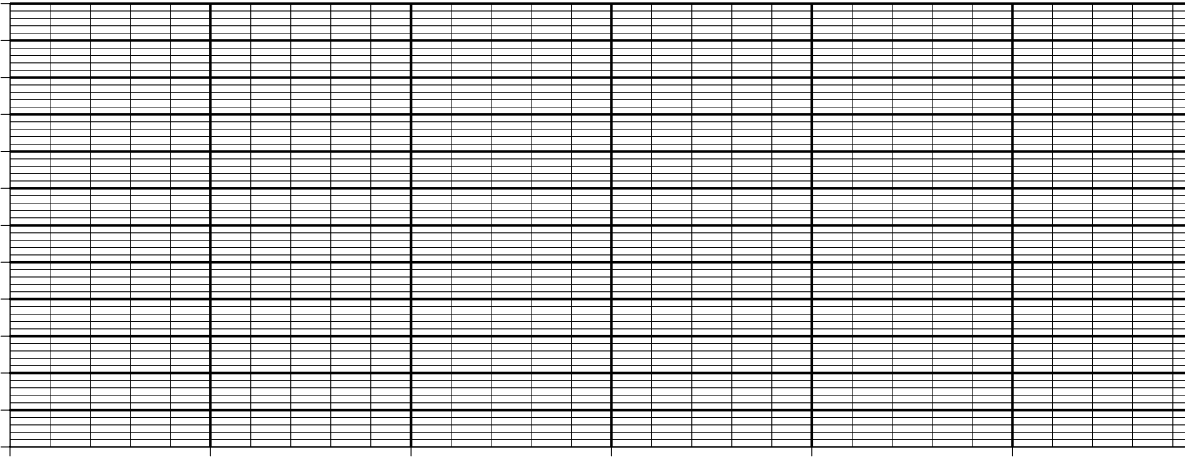

distance (m)

conductivity (mmhos/m)

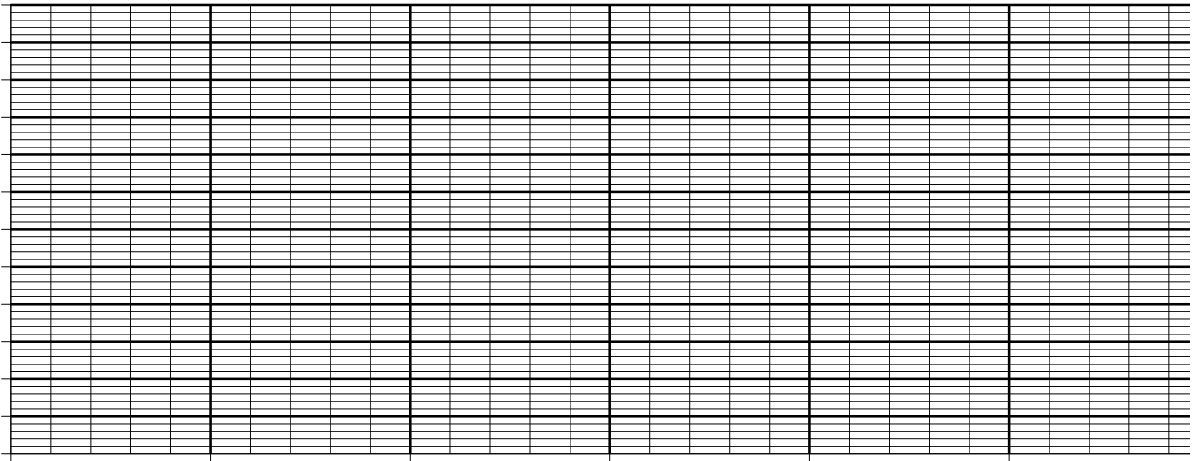

distance (m)

conductivity (mmhos/m)

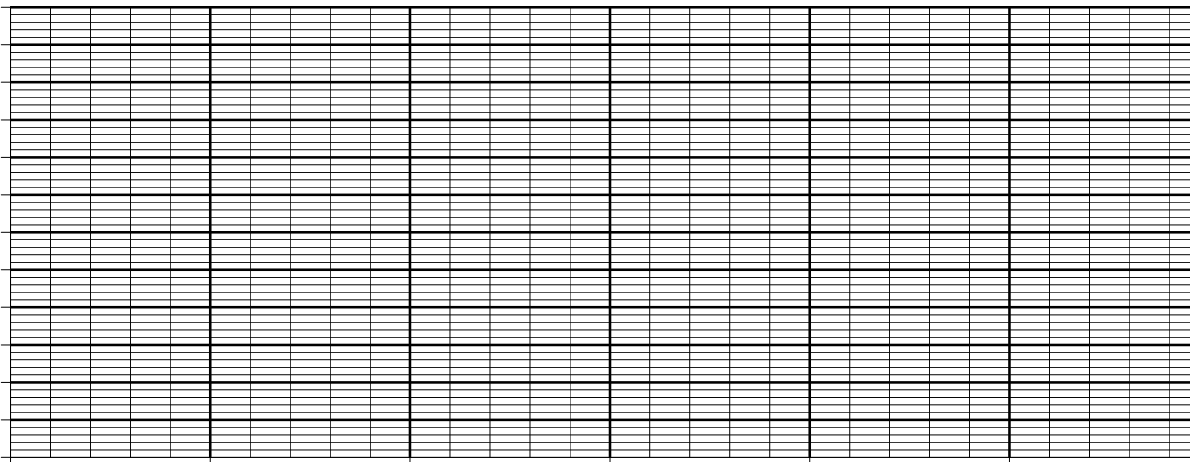

distance (m)

Resistivity Data

General

Resistivity is a useful technique for looking at the variation of resistivity with depth. It has been widely applied in Africa, particularly in basement areas. There are two main survey techniques: the Schlumberger and Wenner arrays. A modification of the Wenner, called the Offset Wenner, is particularly useful. Often an EM34 survey, with 40 m spacings gives nearly as much information as a simple resistivity survey and is much easier to carry out. The purpose of this sheet is not to describe in detail how to carry out resistivity surveys, but to help interpret them if someone else has done them.

Theory

Ground resistivity is measured by passing an electrical current through the ground and measuring the potential difference between two points. Ohms law is then used to calculate the resistance. The resistance is then multiplied by a geometric factor (normally called a **K** factor) to calculate resistivity.

To carry out a depth sounding (VES), electrodes are expanded about a single point. When the electrode spacing is far apart, the electric currents pass deeper into the ground and are therefore measuring the resistance deeper into the ground. A depth sounding tells you information only about one point (the midpoint of the survey). The technique assumes that there are no large lateral variations in the rock type.

Good points and bad points

Resistivity good points	Resistivity bad points
It can identify layers of different resistivity (in other words changes with depth). It can penetrate deep into the ground. It is not affected by tin roofs etc.	Very susceptible to bad electrode connections. Difficult to interpret Laborious and slow. It only takes a reading at one point

Some tips for carrying out a survey

1. Choose an area for the inner electrodes that looks fairly homogeneous.
2. Always make sure the battery is fully charged and carry a spare.
3. Make sure the electrodes are hammered well into the ground and water them. At large electrode spacings a salt solution can be used.
4. For small electrode spacings a small current should be used (< 5 mA). Check that the resistivity is roughly the same at several current settings. If the current is too low, readings will vary.
5. At larger electrode spacings, higher currents are required since they have farther to travel.
6. Plotting the data as you go along allows you to see if any readings are anomalous. A resistivity curve should always look quite smooth.

Interpreting the data

Resistivity data is interpreted by plotting the apparent resistivity against electrode spacing on a log-log scale. This should produce a smooth curve. For a Schlumberger array, the curve will be in several segments. Readings at large electrode spacings refer to the resistivity at depth. Refer to the BGS report CR/01/168N for some examples of interpreting the data qualitatively. To properly interpret the data type curves or computer programmes are required.

IMPORTANT

Resistivity is the inverse of conductivity. Resistivity in Ohm-m is related to conductivity (in mmhos/m) by the formulas:

$$\text{Resistivity} = 1000 / (\text{conductivity})$$

$$\text{Conductivity} = 1000 / (\text{resistivity})$$

Offset Wenner

Village Name:

Survey Number.....

GPS:

Date:

Location:

Name of surveyers:

electrode spacing (m)	terrameter measurements (Ohms)				resistance (D1+D2)/2	K	apparent resistivity
	A	B	C	D1			
0.5						3.14	
1						6.28	
2						12.56	
4						25.12	
8						50.24	
16						100.48	
32						200.96	
64						401.92	
128						803.84	

To check electrodes and cables OK then $A = B + C$ (within 5%)

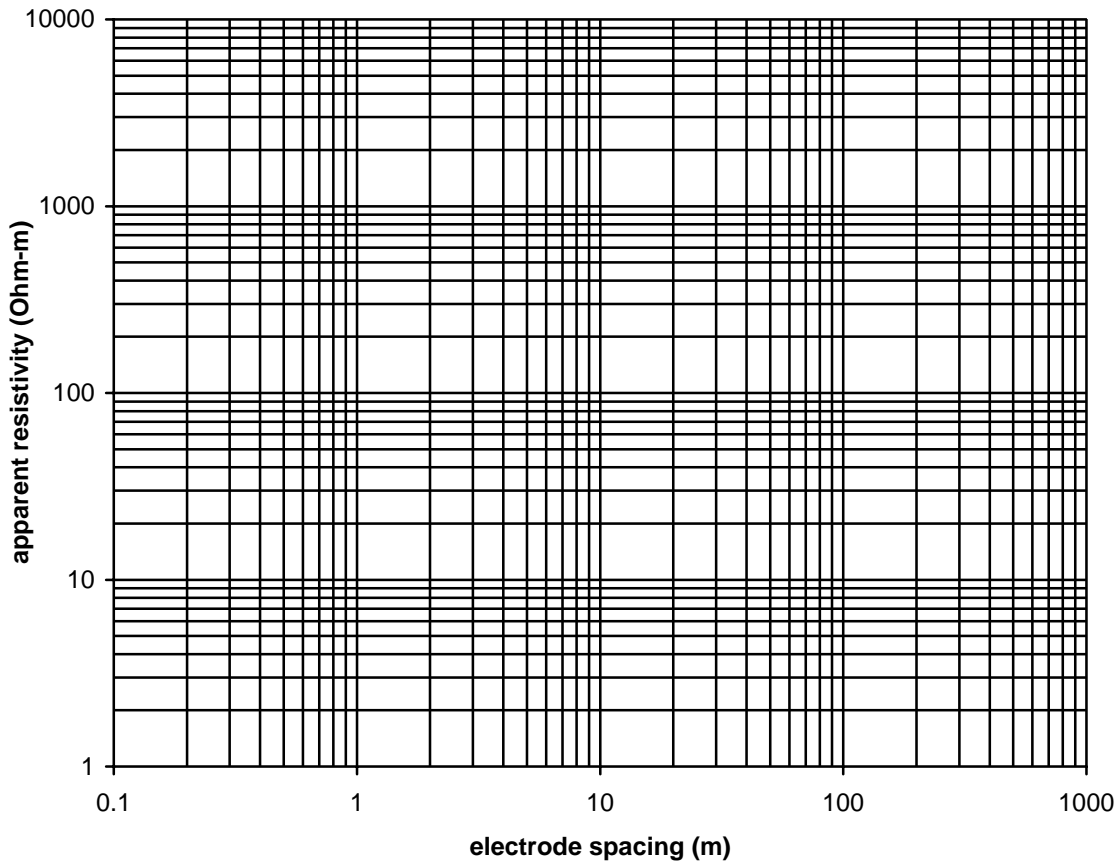

Schlumberger

Village Name:

GPS:

Location:

Survey Number.....

Date:

Name of surveyers:

Outer electrode half spacing (m)	Inner electrode half spacing (m)	resistance Ohms	K*	apparent resistivity
1	0.2		7.54	
1.5	0.2		17.3	
2	0.2		31	
3	0.2		70	
5	0.2		196	
7	0.2		384	
10	0.2		784	
7	1.5		49	
10	1.5		102	
15	1.5		233	
20	1.5		416	
30	1.5		940	
20	5		118	
30	5		275	
50	5		777	
70	5		1530	
100	5		3130	
70	10		754	
100	10		1554	
150	10		3520	
200	10		6260	

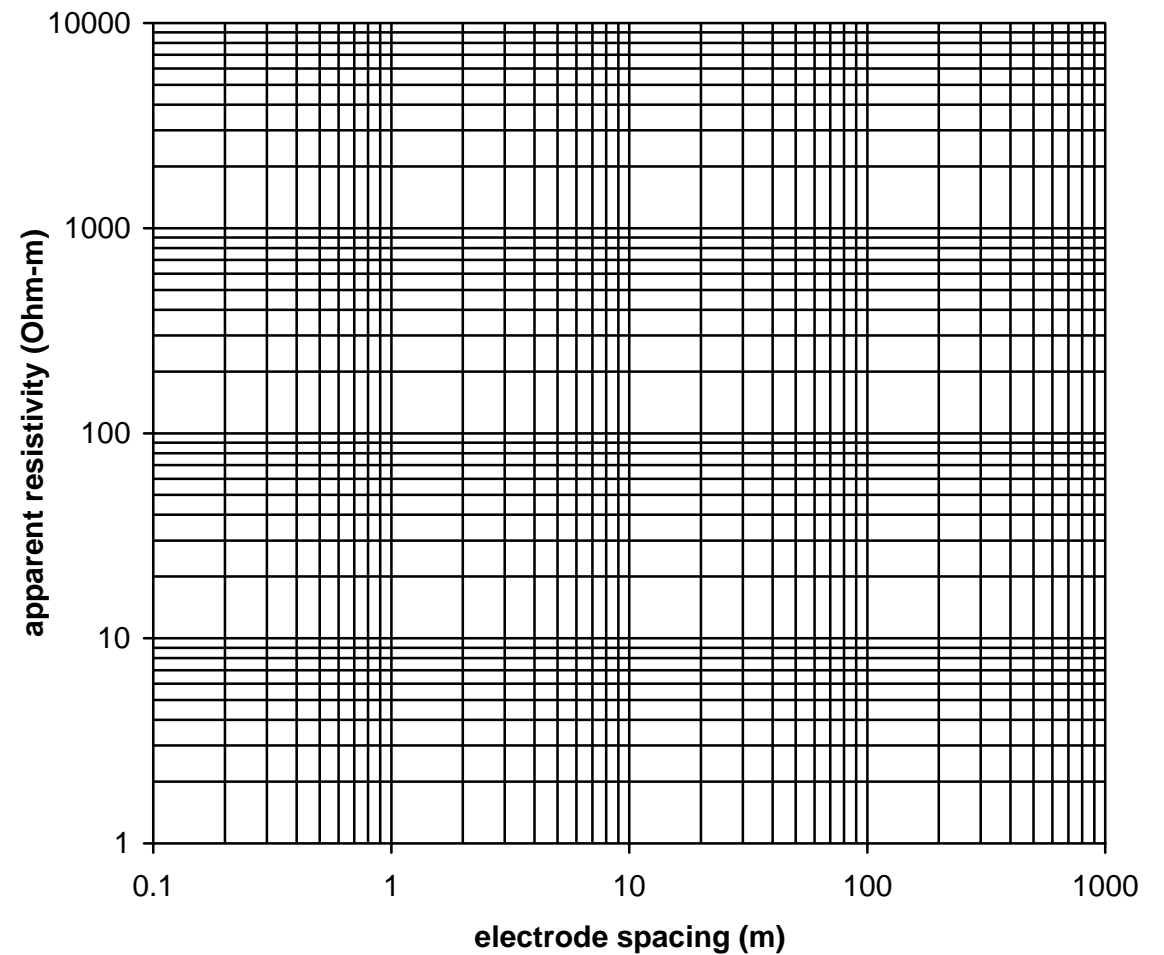

Pumping test analysis: drawdown data

General procedure for carrying out a pumping test

Measure the rest water level in the borehole, and mark the casing where you are taking readings. Switch on the pump, and start the stopwatch at the same time. Water-levels should be measured roughly logarithmically, e.g. every 30 seconds for 0 - 10 minutes, every minute from 10 - 30 minutes, every 5 minutes from 30 - 120 minutes; every 10 minutes from 120 minutes to the end of the test (usually about 300 minutes). Measure the pumping rate often, by timing how long it takes to fill a bucket. If there is a large change in pumping rate, stop the test and start measuring the recovery.

When the pump is switched off, restart the stopwatch, and start measuring the recovery of the water-levels at the same time intervals as for drawdown (e.g. every 30 seconds for 0 - 10 minutes etc...). Keep recording the recovery until water levels have recovered to two-thirds of the maximum drawdown.

Analysis

1. Plot water-levels against time on semi-log paper - time on the log scale, with water-levels on the arithmetic scale (see Figure 1). Either photocopy the semi log graph paper overleaf, or use tracing paper. The time is the number of minutes since pumping started; water-levels should be plotted in metres below casing. The data should plot roughly as a straight line. Draw a best fit line through the data - using mostly the middle or later data (Figure 1).
2. Measure Δs from the best fit line. Δs is the difference in water-levels (in metres) over one log cycle of time (a log cycle is either 1-10; 10-100 or 100-1000).
3. Calculate the average pumping rate (Q) for the pumping test in m^3/d . To change from litres/second, multiply by the number of seconds in a day ($60 \times 60 \times 24$) and divided by the number of litres in a cubic metre (1000).
4. Substitute Q , and Δs into the formula below to find the transmissivity T (measured in m^2/d).

$$T = \frac{0.183 \times Q}{\Delta s}$$

A borehole with a T value of greater than $1 m^2/d$ will generally be successful provided that the borehole is fitted with an India Mk3 (or equivalent)

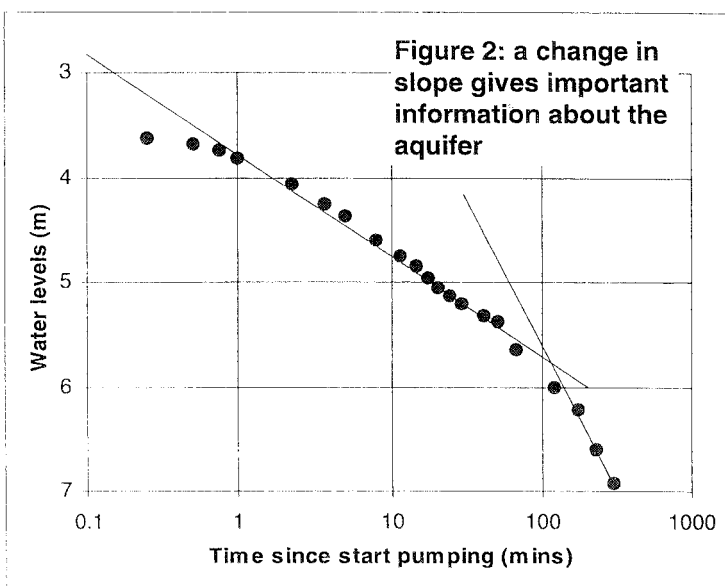
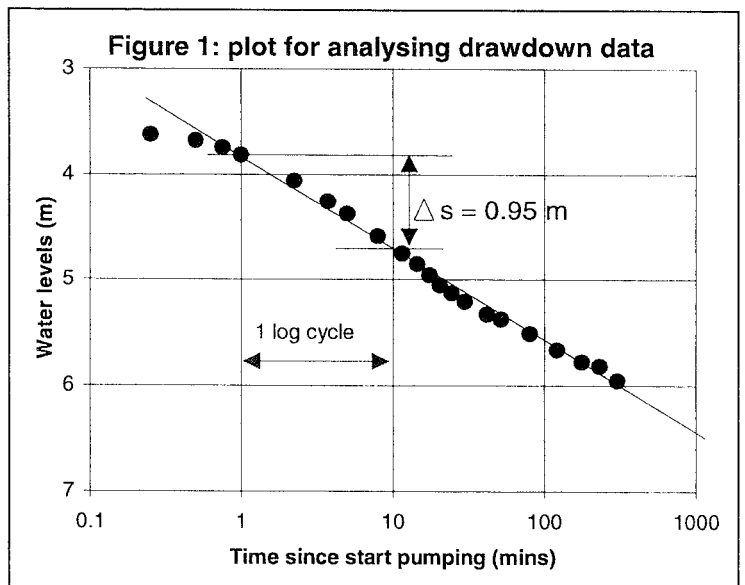

...serving 250 people, requiring 25 litres per day, pumping for 12 hours per day. It is assumed that the storage coefficient of the aquifer is greater than 0.0001, and the pump is set at least 15 m below the rest water level.

Special considerations

If the gradient of the line changes and the rate of decrease of the water levels increases (see Figure 2), a fracture may have been emptied. If possible draw a new line through these points and calculate the transmissivity. If it is less than $1 m^2/d$, the borehole may encounter problems, and not continually sustain a handpump.

Alan MacDonald
January 2000

Pumping test analysis: recovery data

General procedure for carrying out a pumping test

Measure the rest water level in the borehole, and mark the casing where you are taking readings. Switch on the pump, and start the stopwatch at the same time. Water-levels should be measured roughly logarithmically, e.g. every 30 seconds for 0 - 10 minutes, every minute from 10 - 30 minutes, every 5 minutes from 30 - 120 minutes; every 10 minutes from 120 minutes to the end of the test (usually about 300 minutes). Measure the pumping rate often, by timing how long it takes to fill a bucket. If there is a large change in pumping rate, stop the test and start measuring the recovery.

When the pump is switched off, restart the stopwatch, and start measuring the recovery of the water-levels at the same time intervals as for drawdown (e.g. every 30 seconds for 0 - 10 minutes etc...). Keep recording the recovery until water levels have recovered to two-thirds of the maximum drawdown.

Analysis

1. For the recovery part of the test, calculate the residual drawdown (s') by subtracting the rest water level (measured before pumping started) from the measured water-levels.
2. The time elapsed since the start of the recovery is known as t' . For each recovery water-level calculate the time elapsed since the very start of the test (t). For example - if the pump was pumping for 300 minutes before it was switched off, and recovery water levels were measured at 0.5, 1 and 1.5 minutes, t would be 300.5, 301 and 301.5 minutes respectively, and t' , 0.5, 1 and 1.5.
3. Calculate t divided by t' (i.e. t/t')
4. Plot the residual drawdown s' against t/t' on semi-log paper - t/t' on a log scale, with s' on the arithmetic scale. Either photocopy the semi log graph paper overleaf, or use tracing paper. Residual drawdown should be in metres. The data should plot roughly as a straight line. Draw a best fit line through the data - using mostly data from low t/t' values (Figure 1).
5. Measure $\Delta s'$ from the best fit line (see Figure 1). $\Delta s'$ is the difference in water levels over one log cycle of time (a log cycle is either 1-10; 10-100 or 100-1000).
6. Calculate the average pumping rate (Q) for the pumping test in m^3/day . To change from litres/second, multiply by the number of seconds in a day ($60 \times 60 \times 24$) and divided by the number of litres in a cubic metre (1000)..
7. Substitute Q , and $\Delta s'$ into the formula below to find the transmissivity, T (measured in m^2/day).

$$T = \frac{0.183 \times Q}{\Delta s'}$$

Interpretation

A borehole with a T value of greater than $1 m^2/d$ will generally be successful provided that the borehole is fitted with an India Mk3 (or equivalent) serving 250 people, requiring 25 litres per day each, pumping for 12 hours per day. It is assumed that the storage coefficient of the aquifer is greater than 0.0001, and the pump is set at least 15 m below the rest water level. Usual conditions of Theis recovery (confined, homogeneous etc. also apply).

Alan MacDonald
January 2000

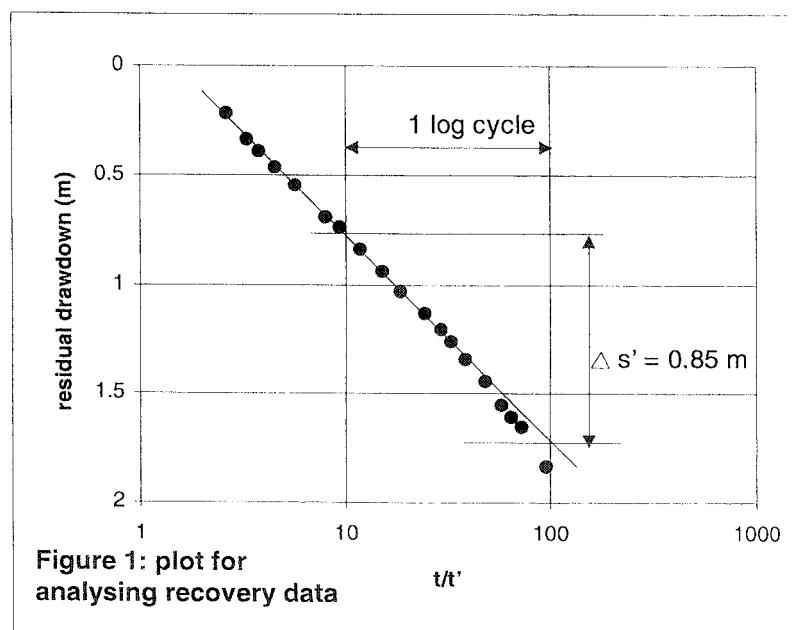

Graph paper for plotting pump test data (recovery or drawdown)

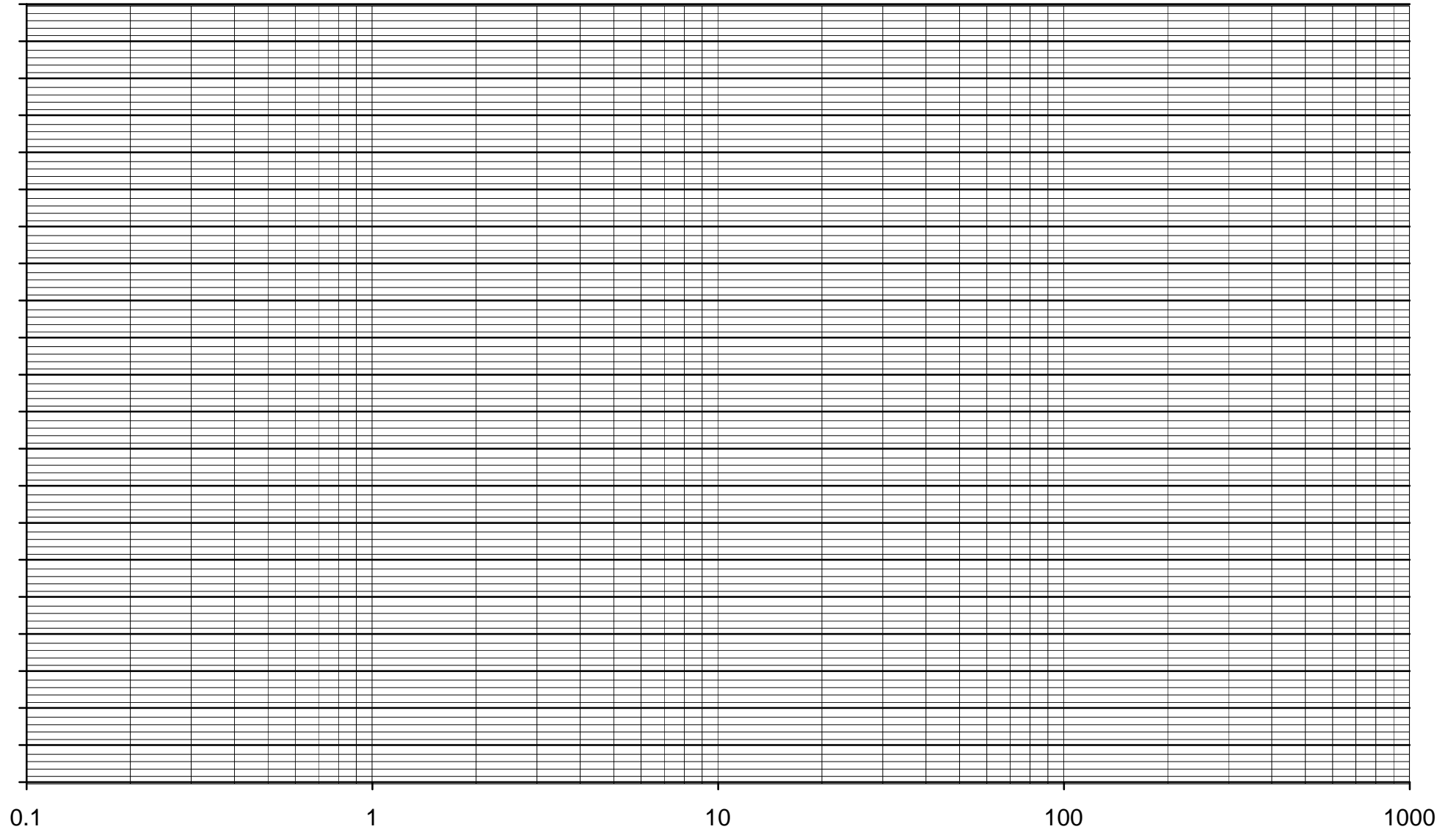

Interpreting the 10 minute bailer test

To interpret the bailer test, follow the steps below

Pumping rate in m^3/d =

$$\frac{\text{volume of bailer (in m}^3\text{) x number of bails}}{\text{time of pumping in days}}$$

Maximum drawdown

A = the earliest reading of water level after pumping stops

B = the rest water level

Maximum drawdown = A - B

Time for 50% recovery (t_{50})

divide the maximum drawdown by 2

add the rest water level

t_{50} is the time at which the water level recovers to the level above (from data overleaf)

Time for 75% recovery (t_{75})

divide the maximum drawdown by 4

add the rest water level

t_{75} is the time at which the water level recovers to the level above (from data overleaf)

Estimate the effective diameter of the borehole.

If it is open hole then this will be the drilled diameter.

If the borehole is screened and gravel packed then the effective diameter will be somewhere between the screen diameter and the drilled diameter. (Generally closer to the screen diameter).

Find the pumping rate and the diameter of the borehole in the table below.

The maximum drawdown, t_{50} and t_{75} for the test must all be **less** than that shown in the table.
 If they are all much greater, then the borehole will have problems sustaining a handpump
 If they are all much less than the table, then the borehole will sustain a handpump
 If some are greater, and some are less then a proper pumping test must be carried out.

		10 m^3/d	15 m^3/d	20 m^3/d	25 m^3/d	30 m^3/d
4 inch	Max drawdown	3.5	5.3	7.1	8.8	10.6
	t_{50} (mins)	6	6	6	6	6
	t_{75} (mins)	14	14	14	14	14
5 inch	Max drawdown	2.9	4.3	5.7	7.1	8.5
	t_{50} (mins)	9	9	9	9	9
	t_{75} (mins)	21	21	21	21	21
6 inch	Max drawdown	2.3	3.4	4.6	5.7	6.9
	t_{50} (mins)	12	12	12	12	12
	t_{75} (mins)	28	28	28	28	28
8 inch	Max drawdown	1.5	2.3	3.1	3.8	4.6
	t_{50} (mins)	19	19	19	19	19
	t_{75} (mins)	46	46	46	46	46